



# STORMWATER MANAGEMENT REPORT

South Jersey Gas  
Interconnect Station  
Mount Pleasant-  
Tuckahoe Road  
Upper Township, NJ

24" Natural Gas  
Pipeline for System  
Reinforcement and to  
Supply the BL England  
Power Plant



---

## STORMWATER MANAGEMENT REPORT

### SOUTH JERSEY GAS INTERCONNECT STATION MOUNT PLEASANT-TUCKAHOE ROAD UPPER TOWNSHIP, NEW JERSEY

Applicant:

**SOUTH JERSEY GAS  
ONE SOUTH JERSEY PLAZA  
FOLSOM, NEW JERSEY 08037**

Prepared By:

**WOODARD & CURRAN  
50 MILLSTONE ROAD, BUILDING 300  
EAST WINDSOR, NEW JERSEY 08520  
877-786-8881**

Submitted:

**JUNE 2014**

Prepared By: **Paul Jacques**

Reviewed By: **Mark Pereira**

---

**Dennis M. Walsh, P.E.**

**NJ Lic. No. GE46534**

## TABLE OF CONTENTS

| SECTION  | PAGE NO.   |
|--|------------|
| <b>1. INTRODUCTION .....</b>                               | <b>1-1</b> |
| <b>2. PROJECT DESCRIPTION .....</b>                        | <b>2-1</b> |
| 2.1 Existing Conditions .....                              | 2-1        |
| 2.2 Proposed Development .....                             | 2-1        |
| 2.3 Proposed Stormwater BMP's .....                        | 2-2        |
| <b>3. STORMWATER MANAGEMENT SYSTEM ANALYSIS.....</b>       | <b>3-1</b> |
| 3.1 Methodology .....                                      | 3-1        |
| 3.2 Pre-Development Hydrologic Analysis .....              | 3-2        |
| 3.3 Post-Development Hydrologic Analysis.....              | 3-2        |
| 3.4 Hydrologic Analysis Results .....                      | 3-3        |
| <b>4. SOIL EROSION AND SEDIMENTATION CONTROL.....</b>      | <b>4-1</b> |
| <b>5. STORMWATER MANAGEMENT STANDARDS COMPLIANCE .....</b> | <b>5-1</b> |

## LIST OF FIGURES

| FIGURE    |                                |
|-----------|--------------------------------|
| Figure 1: | Site Locus Map                 |
| Figure 2: | Pre-Development Watershed Map  |
| Figure 3: | Post-Development Watershed Map |
| Figure 4: | FEMA FIRMETTE                  |

## APPENDICES

| APPENDIX     |  |
|--------------|--|
| Appendix A : | Pinelands Commission Stormwater Checklist                          |
| Appendix B:  | Drawings   |
| Appendix C:  | Test Pit Data and Soils Information                                |
| Appendix D:  | Pre-Development Analysis   |
| Appendix E:  | Post-Development Analysis  |
| Appendix F : | Groundwater Mounding Analysis and System Drawdown Time Calculation |
| Appendix G : | NOAA 24 Hour Rainfall Depths                                       |
| Appendix H : | Stormwater Management System Operations and Maintenance Plan       |

---

## 1. INTRODUCTION

This report describes the Stormwater Management Plan for the proposed South Jersey Gas (the “applicant”) Interconnect Station Site located on the eastern side of Mount Pleasant Road, approximately 900 feet north of the intersection between Mount Pleasant-Tuckahoe Road and Marshall Avenue in Upper Township, New Jersey (the “Site”). The Interconnect Station is part of the applicant’s 24 Inch Natural Gas Pipeline project for system reinforcement and to supply the B.L. England Power Plant. This report has been prepared for the Interconnect Station Site only.

The overall project includes the installation of a new 24 inch diameter steel pipeline to supply natural gas to the existing Beesleys Point coal-fired electric generating plant located in Upper Township, Cape May County, commonly known as the B.L. England Generating Station. The project is necessary to convert the facility from a coal to natural gas fueled generating plant per a State mandated requirement of BL England to discontinue using coal as the primary fuel source for the production of electricity.

The Stormwater Management Plan for the Interconnect Station Site has been developed to demonstrate compliance with the Pinelands Comprehensive Management Plan, Part VIII, Water Quality (the “CMP”), the Upper Township Land Subdivision and Site Plan Regulations, Section 19-7.7, Stormwater Control (the “Municipality Regulations”), the New Jersey Administrative Code, Title 7, Chapter 8 (N.J.A.C. 7:8) and the New Jersey Stormwater Best Management Practices Manual (the “BMP Manual”). The plan describes the existing and proposed conditions at the Site, the stormwater management design and details compliance with the above referenced regulations.

## 2. PROJECT DESCRIPTION

### 2.1 EXISTING CONDITIONS

The Site is identified as Lot 12 on Assessor's Block 350 and is located on the eastern side of Mount Pleasant-Tuckahoe Road, approximately 900 feet north of the intersection between Mount Pleasant-Tuckahoe Road and Marshall Avenue in Upper Township, New Jersey as indicated on Figure 1. The Site area is approximately 6.10 acres and is located within the State Pinelands Area. The property abuts Mount Pleasant-Tuckahoe Road to the west and residential properties to the north, south, and east. The Site consists of the Upper Township Department of Public Works Facility, South Jersey Railroad Museum and two T-ball fields. The proposed Interconnect Station will be located within the existing T-ball field area as shown on Figure A. An easement will be obtained for the Station. Grades on Site slope in a southwesterly direction towards Mount Pleasant Road.

According to the United States Department of Agriculture (USDA) Natural Resources Conservation Service (NRCS) Soil Survey of New Jersey, Site soils consist of Berryland and Mullica soils, 0 to 2 percent slopes, occasionally flooded and are classified as hydrologic soil groups (HSG) B and D.

Soil evaluations were performed at the Site in March of 2014 by Woodard & Curran, in accordance with Item Nos. 3 and 5 of the Pineland Commission Stormwater Checklist and Reference Guide. The evaluations were performed in order to determine the existing soil conditions throughout the Site, water table elevations and the permeability rates to be used to design the proposed stormwater BMP's. The evaluations comprised three test holes and permeability tests as depicted on Figure A. The soil evaluation log forms and permeability test results are provided in Appendix C.

The FEMA Flood Insurance Rate Map (FIRM) for Cape May County, New Jersey, Panel 6 of 20 dated June 1, 1984 indicates that the Site is located within a Zone C flood area. A Zone C flood area is defined by FEMA as "areas of minimal flooding." The FEMA FIRM is included as Figure 4. As of this Plan, the FIRM's for this area have not been updated due to Superstorm Sandy.

### 2.2 PROPOSED DEVELOPMENT

The interconnect station will be located at approximately the mid-way point of the new pipeline and will house below ground piping (24 inch), above ground piping (4, 8, 12 and 24 inch), regulators, control valves and a catalytic heater. The station is being constructed for the following reasons:

- To connect the new proposed 24" - 435 psi gas main to the existing 16" - 250 psi, 8" - 250 psi and 4" - 60 psi gas systems in order to provide reinforcement supply for the existing lines;
- To allow the existing 250 psi system to temporarily provide gas to the BL England service if there is a disruption to the proposed 24" gas main upstream of the station; and
- To locate a heater within the system to prevent the buildup of condensation as the pressure is reduced from 250 psi to 60 psi.

The proposed development associated with the interconnect station consists of the installation of a 21,930 square foot crushed stone area and six foot high fence and gate for security purposes. No new impervious surfaces are proposed with the exception of a bituminous asphalt apron for access purposes along Mount

Pleasant-Tuckahoe Road. The proposed aboveground sections of pipe will be supported by small piers. Stormwater generated from the aboveground piping will runoff directly to the crushed stone below.

### 2.3 PROPOSED STORMWATER BMP'S

The proposed stormwater management system includes a 6 inch crushed stone infiltration area, which promotes infiltration. The proposed system has been designed in accordance with the requirements of the New Jersey BMP Manual to the extent practicable.

The 6 inches of crushed stone will function as an infiltration BMP; collecting and storing stormwater runoff for the majority of the Site prior to infiltration. Given that vehicular access to the Site will be minimal, an asphalt or concrete surface course is not needed.

Based upon the soil evaluation, the majority of soils beneath the infiltration area are classified as loamy sand. The upper topsoil layer will be removed for the installation of the crushed stone. The total depth of the soil evaluations were approximately 7 to 8 feet. The soil evaluations identified a seasonal high groundwater table (SHGWT) at a depth of 52" from existing grade. In general, the top of the infiltration area will be installed at existing grade; therefore the separation distance between the bottom of crushed stone and the SHGWT will be approximately 3.80 feet.

Six permeability tests were performed in accordance with Item No. 5 of the Pineland Commission's Stormwater Checklist and Reference Guide and are provided in Appendix C. The permeability tests resulted in rates ranging from 1.43 to 8.98 inches per hour. The lower permeability rates (1.43 and 1.94 inches per hour) were found within Test Pit No. 2 and appear to be isolated to this area of the system. 1.43 inches per hour was used as the design infiltration rate; however it is anticipated that the net permeability rate for the entire system will be greater than that used for the design.

The proposed BMP is not required to provide stormwater quality and groundwater recharge since no new impervious surfaces are proposed on-Site. Even though it is not required, the crushed stone infiltration area will provide stormwater quality and groundwater recharge benefits.

An Operation and Maintenance Plan has been developed for the proposed stormwater management system. The Operation and Maintenance Plan describes the long term operation and maintenance of the proposed stormwater management system and is included as Appendix F.

### 3. STORMWATER MANAGEMENT SYSTEM ANALYSIS

#### 3.1 METHODOLOGY

A pre- and post-development hydrologic analysis was performed to calculate and compare the peak rate of runoff of the existing and proposed conditions. The analysis was performed using HydroCAD® modeling software, developed by HydroCAD® Software Solutions LLC. The HydroCAD® software is based upon the Soil Conservation Service’s (SCS), *Technical Release 20 – Urban Hydrology for Small Watersheds* (TR-20), which is an industry accepted standard. The HydroCAD® model calculates peak rates of runoff by considering various hydrologic parameters and the stormwater structural measures that directly influence the rate at which runoff is conveyed from a watershed. The hydrologic parameters that were applied to perform these calculations are as follows:

- **Design Event:** The project was evaluated under the 2-, 10-, and 100-year 24-hour SCS Type III Rainfall Events. Rainfall depths associated with each event were obtained from the National Oceanic and Atmospheric Administration (NOAA) (Appendix G) in accordance with the Pinelands Commission CMP and are presented in Table 1.

**Table 1: Rainfall Depths**

| Rainfall Event | Rainfall Depth (inches) |
|----------------|-------------------------|
| 2-year         | 3.35                    |
| 10-year        | 5.21                    |
| 100-year       | 9.00                    |

- **Curve Number:** Curve numbers are specific to each watershed and are a function of the perviousness of the watershed cover, the underlying soil type, and antecedent moisture conditions. Cover types for existing and proposed conditions were found using the Existing and Proposed Conditions Watershed Maps (Figures 2 and 3, respectively). Underlying soil types were identified using the soil data presented in Section 2.1, and an antecedent moisture condition of “2” was assumed. Curve number calculations for each watershed are presented in Appendix D and Appendix E.
- **Time of Concentration:** The time of concentration represents the time for runoff from the most hydrologically distant point of the watershed to reach the discharge location. They are specific to each watershed and are a function of the slope, length, and surface roughness of the flow path. Flow paths for existing and proposed conditions were delineated using the Existing and Proposed Conditions Watershed Maps (Figures 2 and 3, respectively). Calculations for the time of concentration for each watershed are presented in Appendix D and Appendix E.
- **Watershed Area:** Watershed areas were obtained using the watershed boundaries that were delineated using the Existing Conditions Survey and Proposed Site Plan. Watershed boundaries are illustrated on Figure 2 and Figure 3 for existing and proposed conditions, respectively. Areas are included with the hydrologic calculations in Appendix D and Appendix E.

Pre- and post-development peak rates of runoff and volumes were calculated and compared for the Site by considering the aforementioned hydrologic parameters and stormwater measures for each contributing watershed.

### 3.2 PRE-DEVELOPMENT HYDROLOGIC ANALYSIS

The pre- development hydrologic model consists of one watershed area (Watershed A). The Watershed A point of analysis is the westerly property line along Mount Pleasant-Tuckahoe Road. The existing watershed area is shown on Figure 2 and described as follows.

- Existing Watershed A: Existing Watershed A is approximately 1.55 acres. Runoff from this watershed is conveyed via overland flow to Mount Pleasant-Tuckahoe Road. The watershed consists of woodlands, the T-ball fields and grassed areas.

The results of the pre-development analysis are provided in Section 3.4.

### 3.3 POST-DEVELOPMENT HYDROLOGIC ANALYSIS

The post-development hydrologic model divides the Site into two watershed areas based on the proposed topography and the location of the on-site crushed stone infiltration area. Watershed A is divided into two sub-watershed areas, A-1 and A-2. The watersheds are depicted in Figure 3 and described as follows.

- Proposed Watershed A-1: Proposed Watershed A-1 consists of the proposed crushed stone area as well as adjacent upland area and is approximately 0.79 acres. Runoff from this watershed will flow directly into the crushed stone infiltration area and infiltrate into the underlying soils. The crushed stone infiltration area will store and infiltrate runoff for the 2-, 10- and 100-year storm events; therefore Proposed Watershed A-1 will not contribute to off-Site runoff under post-development conditions. For Watershed A-1, the crushed stone area is considered impervious. This approach is conservative.
- Proposed Watershed A-2: Proposed Watershed A-2 consists of the areas surrounding the crushed stone pad draining directly to Mount Pleasant Road and is approximately 0.76 acres. Runoff from this watershed is conveyed via overland flow to Mount Pleasant Road. The Proposed Watershed A-2 area consists of grass and woodlands.

The results of the post-development analysis are provided in Section 3.4.



### 3.4 HYDROLOGIC ANALYSIS RESULTS

The proposed drainage system has been designed such that there will be no increase in pre-development stormwater peak discharge rates and volumes for the 2-, 10- and 100-year storm events at the point of analysis. The HydroCAD® analyses for existing and proposed conditions are included in Appendix D and E, respectively. The net peak discharge rates and volumes are summarized in the tables below.

**Table 2: Watershed A – Peak Flow Rate of Runoff**

| Condition           | Peak Flow Rate of Runoff (cfs) |              |              |
|---------------------|--------------------------------|--------------|--------------|
|                     | 2-year                         | 10-year      | 100-year     |
| Existing Conditions | 0.54                           | 2.01         | 6.00         |
| Proposed Conditions | 0.28                           | 0.99         | 4.15         |
| <b>Difference</b>   | <b>-0.26</b>                   | <b>-1.02</b> | <b>-1.85</b> |

**Table 3: Watershed A – Stormwater Volume**

| Condition           | Stormwater Volume (ac-ft) |               |               |
|---------------------|---------------------------|---------------|---------------|
|                     | 2-year                    | 10-year       | 100-year      |
| Existing Conditions | 0.071                     | 0.203         | 0.561         |
| Proposed Conditions | 0.037                     | 0.104         | 0.317         |
| <b>Difference</b>   | <b>-0.034</b>             | <b>-0.099</b> | <b>-0.244</b> |

The tables above demonstrate that the post-development stormwater peak flow rates and volumes are less than existing conditions for the 2-, 10- and 100- year storm events.

---

#### 4. SOIL EROSION AND SEDIMENTATION CONTROL

Soil erosion and sedimentation control measures will be installed, inspected and maintained at the Site in accordance with the standards set forth in the Soil Erosion and Sediment Control Act, N.J.S.A. 4:24-39. An *Application for Soil Erosion and Sediment Control Plan Certification* will be prepared and submitted to the Cape Atlantic Soil Conservation District for approval prior to the start of construction.

Prior to and during construction, the following temporary soil erosion and sedimentation control measures will be constructed and maintained:

- Perimeter Controls: A siltation barrier consisting of a filter fabric silt fence will be installed in advance of construction along the perimeter of the Site in locations shown on the Site Layout Plan (Appendix B). During construction, the barrier should be inspected weekly, immediately after each runoff-producing rainfall event and at least daily during prolonged rainfall. Sediment deposits must be removed when the depth of sediment reaches approximately one-half the height of the barrier.
- Construction Entrance: A temporary construction entrance is proposed to prevent the tracking of sediment off-Site. The entrance should be maintained in a condition that will prevent the tracking of sediment onto Mt. Pleasant-Tuckahoe Road right-of-way. The entrance should be inspected weekly and after heavy rainfall events or use.

## 5. STORMWATER MANAGEMENT STANDARDS COMPLIANCE

This section discusses the project's compliance with the 16 Items set forth in the Pinelands Stormwater Checklist. A summary of each Item is provided below (in italics) for reference purposes, and a description regarding the project's compliance with the standard is also provided in bold.

Item No. 1: *Calculations demonstrating that the proposed development meets one of the following three stormwater runoff rate standards:*

- *Post-development hydrographs for the 2, 10 and 100-year storms of 24-hour duration will not exceed the predevelopment runoff hydrographs at any point in time [N.J.A.C. 7:50-6.84(a)6ii(1)].*
- *Any increased stormwater runoff volume or change in stormwater runoff timing for the two (2), ten (10), and one hundred (100)-year storms will not increase flood damage at or downstream of the project Site.*
- *The peak post-development runoff from the 2, 10 and 100-year storms will be 50%, 75% and 80% respectively of the pre-development peak rates for the same storms [N.J.A.C. 7:50-6.84(a)6ii(3)].*

**The proposed drainage system has been designed such that there will be no increase in pre-development peak discharge rates and stormwater volumes for the 2, 10 and 100 year storm events at the points of analysis.**

Item No. 2: *Calculations demonstrating that the total runoff volume generated from the net increase in impervious surfaces by a 10-year storm of 24-hour duration will be retained and infiltrated on Site.*

**No new impervious surfaces are proposed; therefore calculations demonstrating that the total runoff volume generated from the net increase in impervious surfaces by a 10-year storm of 24-hour duration will be retained and infiltrated on Site are not required.**

Item No. 3: *Information (soil logs) demonstrating that the lowest point of infiltration of each structural stormwater management measure (e.g. swales, basins, drywells) will meet the two foot separation to the seasonal high groundwater table (SHWT) standard.*

**Three soil evaluations were performed within the crushed stone infiltration area footprint in accordance with Item No. 3 of the Pineland Commission's Stormwater Checklist Reference Guide and are provided in Appendix C. The soil evaluation locations are depicted on Figure A. The separation distance between the bottom of crushed stone and the SHGWT will be approximately 3.80 feet**

Item No. 4: *Information demonstrating that the proposed stormwater design will meet the wetland, required buffer to wetlands and surface water protection standards.*

**No wetlands or associated buffers are located on-Site.**

Item No. 5: *Information demonstrating that the soil suitability (permeability rate) standard will be met for all stormwater infiltration facilities (e.g. swales, basins, drywells).*

**Six permeability tests were performed in accordance with Item No. 5 of the Pineland Commission's Stormwater Checklist and Reference Guide and are provided in Appendix C. The permeability tests resulted in rates ranging from 1.43 to 8.98 inches per hour; therefore the existing soils on-Site meet the minimum requirements for an infiltration BMP per the Checklist. 1.43 inches per hour was used as the design infiltration rate.**

Item No. 6: *If the development includes High Pollutant Loading Areas (HPLAs) such as gas stations or vehicle maintenance facilities, information which demonstrates that the HPLA standards will be met is submitted.*

**The project does not include a land use that is considered a High Pollutant Loading Area.**

Item No. 7: *The groundwater mounding standards will be met.*

**A groundwater mounding analysis was conducted using the Hantush method. The results show a maximum increase in the groundwater table beneath the proposed BMP of 0.51 feet. The results of the analysis confirm that the proposed BMP will not break out to the land surface or cause adverse impacts to the surrounding area. Refer to Appendix F.**

Item No. 8: *Information demonstrating that all of the following low impact stormwater design standards will be met (as applicable – see Reference Guide):*

- *Pretreatment of stormwater, prior to entering infiltration measures has been incorporated into the design;*

**No new impervious surfaces are proposed; therefore pretreatment of stormwater prior to entering the crushed stone infiltration area is not required.**

- *The design utilizes multiple, smaller stormwater management measures dispersed spatially throughout the Site.*

**This requirement is not practical given the small size of the proposed Site.**

- *The design incorporates non-structural stormwater management strategies identified in the NJDEP stormwater regulations to the maximum extent practical. A written description of each of these strategies must be provided. Alternatively, the results of the NJDEP's NSPS Spreadsheet or Low Impact Design (LID) Checklist may be submitted.*

**This requirement is not practical given the small size of the proposed Site.**

Item No. 9: *No direct discharge of stormwater to farm fields will occur to the maximum extent practical.*

**No direct discharge of stormwater to farm fields will occur.**

Item No. 10: *The Total Suspended Solids (TSS) load in the stormwater will be reduced by 80%.*

**No new impervious areas are proposed on-Site; therefore no stormwater quality measures are required.**

Item No. 11: *Stormwater management measures have been designed to reduce the nutrient load in the stormwater runoff from the post-developed Site to the maximum extent practical.*

**The majority of stormwater runoff from the Site will be stored within the crushed stone infiltration area prior to infiltration. Runoff from the western most portions of the Site to the Mount Pleasant-Tuckahoe Road right-of-way will be from the perimeter grassed areas. The crushed stone infiltration area will function as a pervious pavement. Per Table 4.2 of the New Jersey BMP Manual, pervious paving provides a Total Phosphorous Removal Rate of 60% and a Total Nitrogen Removal Rate of 50%.**

Item No. 12: *The development will meet the groundwater recharge standards*

**No new impervious areas are proposed on-Site; therefore groundwater recharge measures are not required.**

Item No. 13: *The stormwater management plan addresses stormwater facilities construction and as-built requirement standards.*

**A sequence of construction and as-built requirements are outlined on the Site Plans. Refer to Appendix B.**

Item No. 14: *The proposed stormwater management measures meet structural design standards.*

**The proposed BMP has been designed in accordance with the New Jersey DEP BMP Manual to the extent practicable. The crushed stone infiltration area is designed to drain the total runoff volume generated by the systems maximum design storm within 72 hours. Refer to Appendix F for the system drawdown calculations.**

Item No. 15: *The development meets stormwater facility safety standards.*

**Stormwater facility safety standards are not applicable to the proposed BMP.**

Item No. 16: *A stormwater facilities maintenance plan is provided.*

**A Stormwater Management System Operation & Maintenance Plan is provided in Appendix H.**

---

**Figure 1: Site Locus Map**

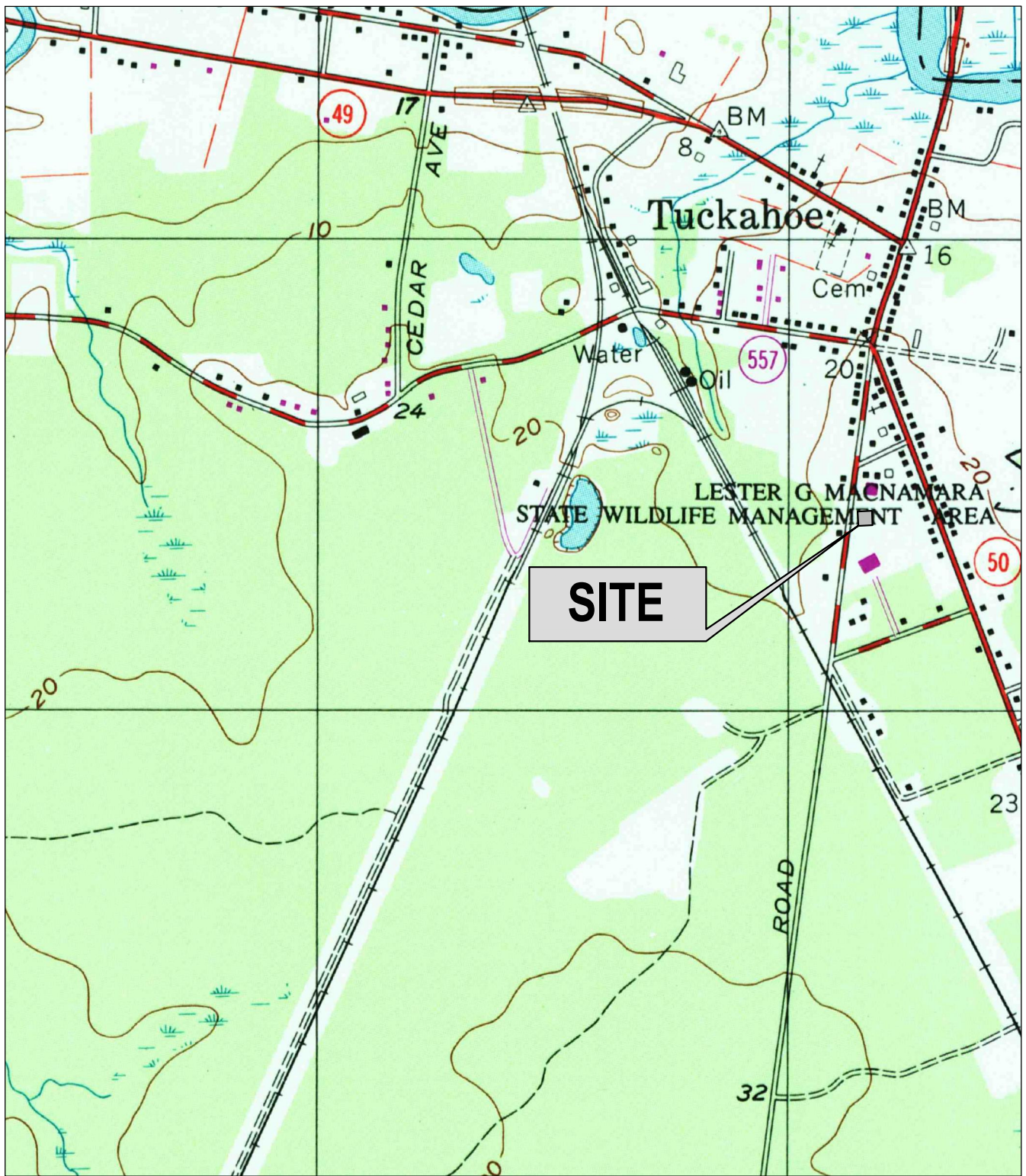

BAR SCALE  
 1" = 1000'  
 CHECK GRAPHIC SCALE BEFORE USING



50 MILLSTONE ROAD  
 EAST WINDSOR, NEW JERSEY 08520  
 877.786.8881 | www.woodardcurran.com

COMMITMENT & INTEGRITY DRIVE RESULTS

SITE LOCUS

DESIGNED BY: NFC      CHECKED BY: PJJ  
 DRAWN BY: NFC         225616-Site Locus.dwg

SOUTH JERSEY GAS  
 PROPOSED 24" NATURAL GAS PIPE

INTERCONNECT STATION

JOB NO: 225616  
 DATE: MAY 2014  
 SCALE: 1" = 1,000'

FIGURE 1

---

**Figure 2: Pre-Development Watershed Map**



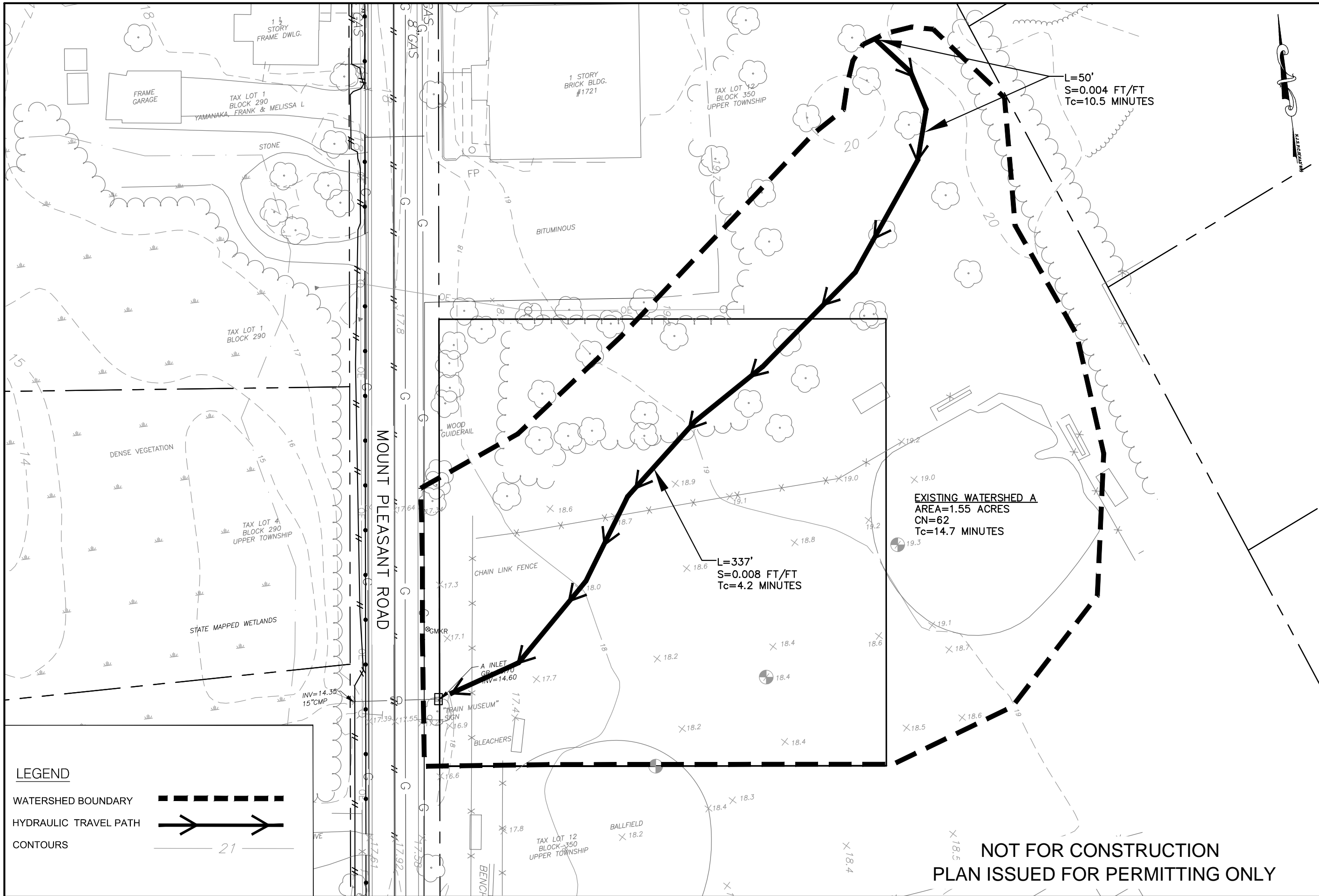

50 Millstone Road, Building 300  
 East Windsor, New Jersey 08520  
 877.766.8881 | www.woodardcurran.com  
**WOODARD & CURRAN**  
 COMMITMENT & INTEGRITY DRIVE RESULTS

**EXISTING CONDITION WATERSHED MAP**  
 DESIGNED BY: PJJ  
 CHECKED BY: PJJ  
 DRAWN BY: NFC  
 225616 EX WATERSHEDS.DWG

SOUTH JERSEY GAS  
 1 SOUTH JERSEY PLAZA  
 FOLSOM, NJ 08037  
  
 PROPOSED 24" NATURAL GAS PIPELINE  
 FOR SYSTEM REINFORCEMENT AND TO  
 SUPPLY B.I. ENGLAND POWER PLANT  
 JOB NO: 225616  
 DATE: MAY 2014  
 SCALE: 1"=40'  
**FIGURE 2**

NOT FOR CONSTRUCTION  
 PLAN ISSUED FOR PERMITTING ONLY

225616 Ex Watersheds.dwg

**Figure 3: Post-Development Watershed Map**

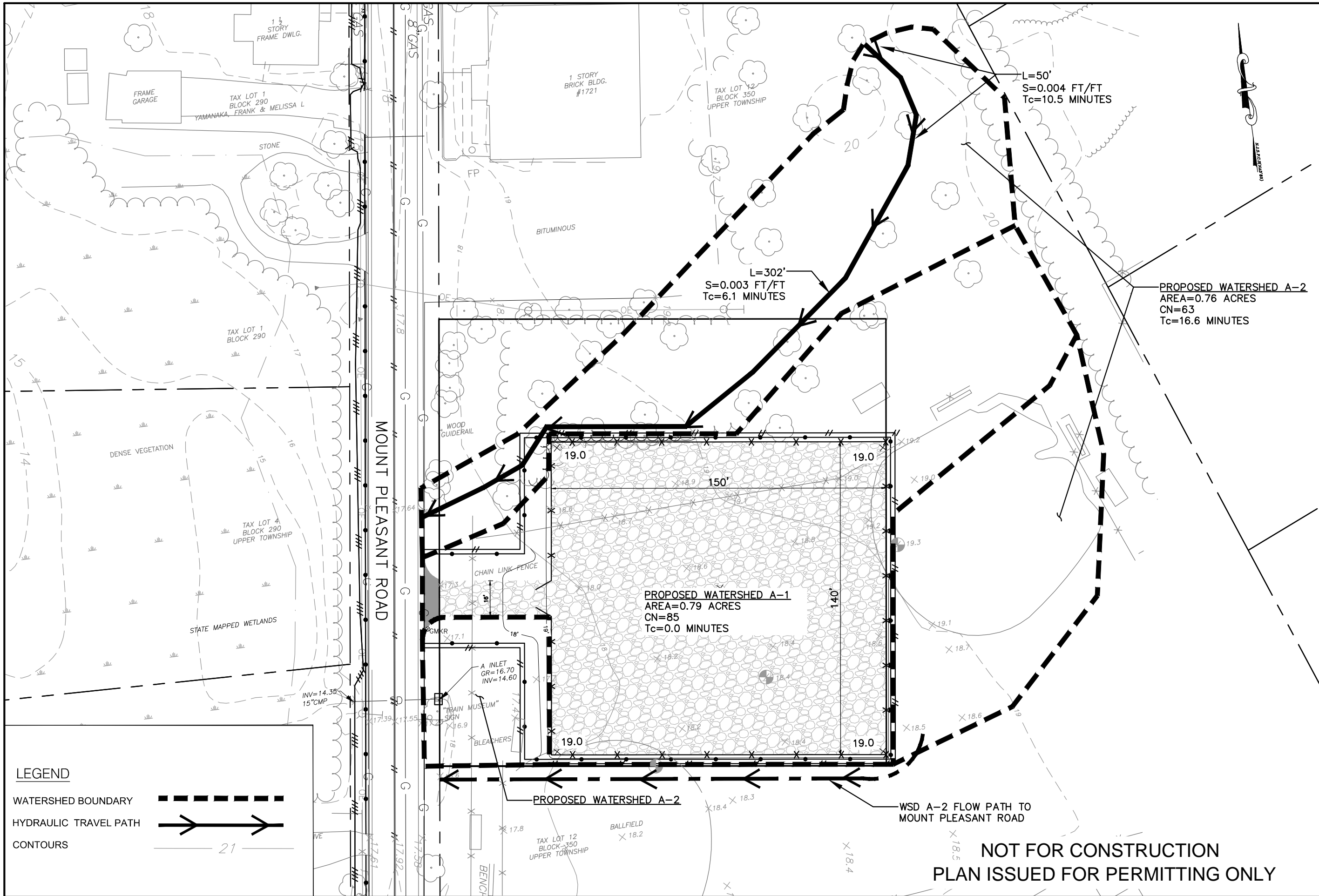

50 Millstone Road, Building 300  
 East Windsor, New Jersey 08520  
 877.766.8881 | www.woodardcurran.com

**WOODARD & CURRAN**

COMMITMENT & INTEGRITY DRIVE RESULTS

**PROPOSED CONDITION  
 WATERSHED MAP**

DESIGNED BY: PJJ  
 CHECKED BY: PJJ  
 DRAWN BY: NFC

225616 EX WATERSHEDS.DWG

SOUTH JERSEY GAS  
 1 SOUTH JERSEY PLAZA  
 FOLSOM, NJ 08037

PROPOSED 24" NATURAL GAS PIPELINE  
 FOR SYSTEM REINFORCEMENT AND TO  
 SUPPLY B.I. ENGLAND POWER PLANT

JOB NO: 225616  
 DATE: MAY 2014  
 SCALE: 1"=40'

**FIGURE 3**

225616 - EX - Watersheds.dwg

---

**Figure 4: FEMA FIRMETTE**

This is an official copy of a portion of the above referenced flood map. It was extracted using F-MIT On-Line. This map does not reflect changes or amendments which may have been made subsequent to the date on the title block. For the latest product information about National Flood Insurance Program flood maps check the FEMA Flood Map Store at www.msc.fema.gov

Federal Emergency Management Agency



MAP REVISED:  
JUNE 1, 1984

COMMUNITY-PANEL NUMBER  
340159 0006 B

FIGURE 4

(SEE MAP INDEX FOR PANELS NOT PRINTED)

PANEL 6 OF 20

TOWNSHIP OF  
UPPER,  
NEW JERSEY  
CAPE MAY COUNTY

**FIRM**  
FLOOD INSURANCE RATE MAP

NATIONAL FLOOD INSURANCE PROGRAM

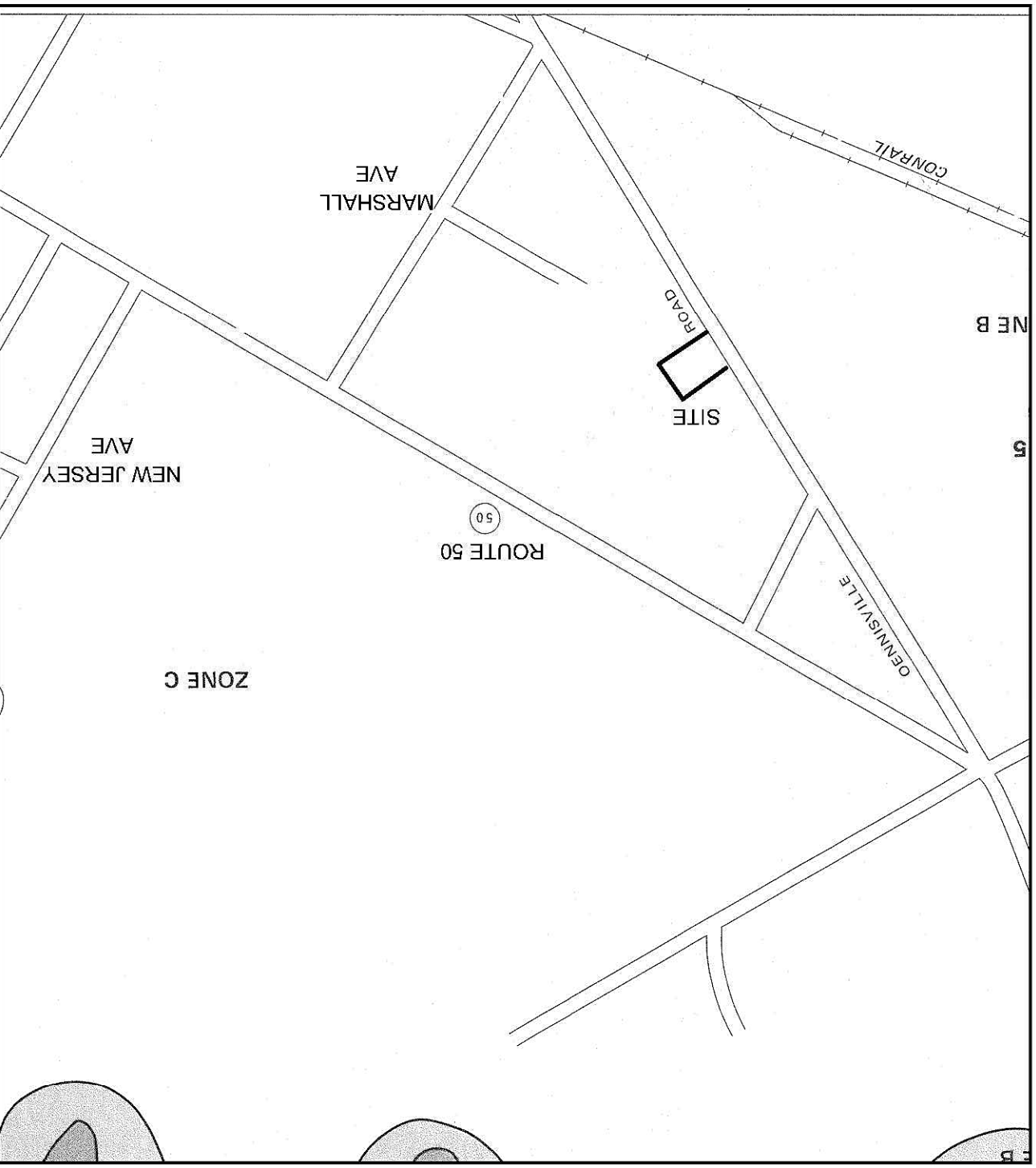
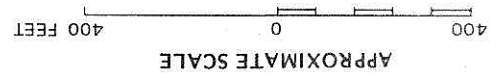

## **APPENDIX A : PINELANDS COMMISSION STORMWATER CHECKLIST**

**STORMWATER CHECKLIST**  
**(Part 1)**

**Stormwater Management Information Required to Be Submitted to  
Commission and Municipality for Review**

The following checklist identifies the stormwater management standards that an applicant must address to complete an application with the Pinelands Commission and the concerned municipality (each “Item #” is cross-referenced in the attached Reference Guide).

Note that the stormwater management standards need not be addressed if either:

- The proposed development is minor residential development, resulting in less than five lots or dwelling units, *and* the development does not involve the construction of any new roads; *OR*
- The development proposed is minor non-residential development, *and* the development does not involve the grading, clearing or disturbance of an area in excess of 5,000 square feet within any five-year period.

| <b>Item #</b> | <b>Addressed</b>                    | <b>Description</b>   |
|---------------|-------------------------------------|--|
| <b>1.</b>     | <input checked="" type="checkbox"/> | <b>Calculations demonstrating that the proposed development meets one of the following three stormwater runoff rate standards:</b>   |
|               | <input checked="" type="checkbox"/> | Post-development hydrographs for the 2, 10 and 100-year storms of 24-hour duration will not exceed the predevelopment runoff hydrographs at any point in time [N.J.A.C. 7:50-6.84(a)6ii(1)].   |
|               | <input type="checkbox"/>            | No increase in pre-development rates from the 2, 10 and 100 year storms will occur. In addition, any increase in stormwater volume for these storms will not increase flood damage at or downstream of the parcel [N.J.A.C. 7:50-6.84(a)6ii(2)]. |
|               | <input type="checkbox"/>            | The peak post-development runoff from the 2, 10 and 100-year storms will be 50%, 75% and 80% respectively of the pre-development peak rates for the same storms [N.J.A.C. 7:50-6.84(a)6ii(3)].   |
| <b>2.</b>     | <input type="checkbox"/> NA         | <b>Calculations demonstrating that the total runoff volume generated from the net increase in impervious surfaces by a 10-year storm of 24-hour duration will be retained and infiltrated on site.</b>   |
|               |                                     | <b>NA (No new impervious surfaces are proposed)</b>  |
| <b>3.</b>     | <input checked="" type="checkbox"/> | <b>Information (soil logs) demonstrating that the lowest point of infiltration of each structural stormwater management measure (e.g. swales, basins, drywells) will meet the two foot separation to</b>   |

| Item # | Addressed                           | Description   |
|--------|-------------------------------------|---|
|        |                                     | <b>the seasonal high water table (SHWT) standard.</b>   |
| 4.     | <input type="checkbox"/> NA         | <b>Information demonstrating that the proposed stormwater design will meet the wetland, required buffer to wetlands and surface water protection standards.</b>   |
|        |                                     | <b>NA (No wetlands or setbacks located on site)</b>   |
| 5.     | <input checked="" type="checkbox"/> | <b>Information demonstrating that the soil suitability (permeability rate) standard will be met for all stormwater infiltration facilities (e.g. swales, basins, drywells).</b>   |
| 6.     | <input type="checkbox"/> NA         | <b>If the development includes High Pollutant Loading Areas (HPLAs) such as gas stations or vehicle maintenance facilities, information which demonstrates that the HPLA standards will be met is submitted.</b>  |
| 7.     | <input checked="" type="checkbox"/> | <b>The groundwater mounding standards will be met.</b>  |
| 8.     | <input type="checkbox"/> NA         | <b>Information demonstrating that all of the following low impact stormwater design standards will be met (as applicable – see Reference Guide):</b>  |
|        | <input type="checkbox"/> NA         | Pretreatment of stormwater, prior to entering infiltration measures, has been incorporated into the design.   |
|        | <input type="checkbox"/> NA         | The design utilizes multiple, smaller stormwater management measures dispersed spatially throughout the site.   |
|        | <input type="checkbox"/> NA         | The design incorporates non-structural stormwater management strategies identified in the NJDEP stormwater regulations to the maximum extent practical. A written description of each of these strategies must be provided. Alternatively, the results of the NJDEP's NSPS Spreadsheet or Low Impact Design (LID) Checklist may be submitted. |



(PART 2)

**Additional Stormwater Management Information Required to Be Submitted to Municipality for Review**

The following checklist identifies certain stormwater management standards that an applicant must address with the municipality (each “Item #” is cross-referenced in the attached Reference Guide). Note that there may be additional information that is required by a municipal ordinance that is not identified in this Pinelands Commission Checklist and Reference Guide.

| <b>Item #</b> | <b>Addressed</b>                    | <b>Description</b>   |
|---------------|-------------------------------------|--|
| 9.            | <input type="checkbox"/> NA         | <b>No direct discharge of stormwater to farm fields will occur to the maximum extent practical.</b>  |
| 10.           | <input type="checkbox"/> NA         | <b>The Total Suspended Solids (TSS) load in the stormwater will be reduced by 80%.</b><br><b>NA (No new impervious surfaces are proposed)</b>  |
| 11.           | <input type="checkbox"/> NA         | <b>Stormwater management measures have been designed to reduce the nutrient load in the stormwater runoff from the post-developed site to the maximum extent practical.</b><br><b>NA (No new impervious surfaces are proposed)</b> |
| 12.           | <input type="checkbox"/> NA         | <b>The development will meet the groundwater recharge standards.</b><br><b>NA (No new impervious surfaces are proposed)</b>  |
| 13.           | <input checked="" type="checkbox"/> | <b>The stormwater management plan addresses stormwater facilities construction and as-built requirement standards.</b>   |
| 14.           | <input checked="" type="checkbox"/> | <b>The proposed stormwater management measures meet structural design standards.</b>   |
| 15.           | <input type="checkbox"/> NA         | <b>The development meets stormwater facility safety standards.</b>   |
| 16.           | <input checked="" type="checkbox"/> | <b>A stormwater facilities maintenance plan is provided.</b>   |

## REFERENCE GUIDE

Each Item # identified in Part 1 and Part 2 (the Checklists) corresponds to the Item # in this Reference Guide.

---

**Item #1.** The CMP [NJAC 7:50-6.84(a)6ii] provides that stormwater management runoff rate standards may be met through one of the following three options:

**I.** Demonstrate that the post-developed stormwater runoff hydrographs from the project site for the 2, 10, and 100-year storms do not exceed, at any point in time, the site's pre-developed runoff hydrographs for the same storms [(NJAC 7:50-6.84(a)6ii(1)]; or

**II.** Demonstrate that under post-developed site conditions [(NJAC 7:50-6.84(a)6ii(2))]:

- a. There is no increase in pre-developed stormwater runoff rates from the project site for the two (2), ten (10), and one hundred (100)-year storms; and
- b. Any increased stormwater runoff volume or change in stormwater runoff timing for the two (2), ten (10), and one hundred (100)-year storms will not increase flood damage at or downstream of the project site; or

**III.** Demonstrate that the peak post-developed stormwater runoff rates from the project site for the two (2), ten (10) and one hundred (100) year storms are fifty, seventy-five and eighty percent (50%, 75% and 80%), respectively, of the site's peak pre-developed stormwater runoff rates for the same storms [(NJAC 7:50-6.84(a)6ii(3))]. Peak outflow rates from onsite stormwater measures for these storms shall be adjusted where necessary to account for the discharge of increased stormwater runoff rates and/or volumes from project site areas not controlled by the onsite measures. These percentages do not have to be applied to those portions of the parcel where development is not currently proposed, provided that such areas:

- a. Are protected from future development by imposition of a conservation easement, deed restriction, or other acceptable legal measures; or
- b. Are subject to review under these standards if they are proposed for any degree of development in the future.

▶ WHAT TO SUBMIT TO THE COMMISSION AND MUNICIPALITY:

- √ A stormwater management plan prepared as follows:
  - a. Runoff rates and volumes calculated in accordance with TR-55 and which utilizes an appropriate hydrograph. An alternative method may be utilized, provided that

information is submitted which demonstrates that the methods of the alternative method are at least as protective as the NRCS methodology.

- b. Stormwater runoff calculated by separately calculating then combining runoff from pervious and directly connected impervious areas within each drainage area.
- c. Calculations of runoff from unconnected impervious surfaces, based on the Two-Step Method described in the NJDEP's BMP Manual.
- d. Rainfall data in the stormwater calculations shall use appropriate 24-hour rainfall depths as developed for the project site by the National Oceanic and Atmospheric Administration, available online at: <http://hdsc.nws.noaa.gov/hdsc/pfds/index.html>.
- e. Pre-development runoff CN values have been assumed to be woods in good condition, or follow standard criteria noted in the NJDEP Stormwater Regulations (N.J.A.C. 7:8 5.6(a)2) as follows:
  - When selecting or calculating Runoff Curve Numbers (CNs) for pre-developed project site conditions, the project site's land cover shall be assumed to be woods in good condition. Another land cover may be used to calculate runoff coefficients if such land cover has existed at the site or portion thereof without interruption for at least five (5) years immediately prior to the time of application and the design engineer can document the character and extent of such land cover through the use of photographs, affidavits, and/or other acceptable land use records. If more than one land cover has existed on the site during the five (5) years immediately prior to the time of application, the land cover with the lowest runoff potential shall be used for the computations. All pre-developed land covers shall be assumed to be in good hydrologic condition and, if cultivated, shall be assumed to have conservation treatment.
  - Where tailwater will affect the hydraulic performance of a stormwater management measure, the design engineer shall include such effects in the measure's design.
- f. In calculating pre-developed site stormwater runoff, the design engineer shall include the effects of all land features and structures such as ponds, wetlands, depressions, hedgerows, and culverts that affect pre-developed site stormwater runoff rates and/or volumes.
- g. Calculations submitted for the purposes of demonstrating consistency with the stormwater volume and rate standards of the CMP shall not include any credit for infiltration in any stormwater BMP during the 2, 10 or 100-year storm events.

- h. Pre and post-development drainage areas maps have been provided which identify the concentration pathways. The maps and calculations include all applicable off-site and on-site areas.
- i. Tc and CN calculations have been provided.
- j. Information is provided for each stormwater management measure which demonstrates how each was designed in accordance with the guidance provided by the NJDEP's BMP Manual.

√ Identify which of the three above noted stormwater rate provisions is being addressed to meet the stormwater runoff standards [NJAC 7:50-6.84(a)6ii(1, 2 or 3)].

√ A written narrative to accompany the above calculations describing the method that was utilized to complete the calculations and that includes the size of each drainage area, the pre-development runoff rates of each drainage area, the post-development runoff rates and volumes generated, the routed rates and volume of runoff for each storm event.

√ If proposing to demonstrate compliance utilizing NJAC 7:50-6.84(a)6ii(1), applicants must provide copies of all pre- and post-development hydrographs. NA If proposing to demonstrate compliance utilizing NJAC 7:50-6.84(a)6ii(2), applicants must provide a build-out analysis for each of the affected drainage areas. When performing this analysis for pre-developed site conditions, all off-site development levels must reflect existing conditions. When performing this analysis for post-developed site conditions, all off-site development levels must reflect full development of the affected drainage area in accordance with current zoning and land use ordinances.

NA If proposing to address the stormwater runoff rate standards utilizing NJAC 7:50-6.84(a)6ii(3), applicants must provide the post development runoff rate reductions for the 2, 10 and 100 year storms (minimum reductions of 50%, 75% and 80%, respectively). If portions of the parcel are not included in the rate calculations because they will remain vacant, the applicant must either:

- a. Indicate whether a recorded deed restriction will be imposed on that portion of the site not to be developed, or
- b. Provide a note on the plans indicating that any development proposed in these areas in the future must meet the stormwater standards in place at that time.

**Item #2.** The total runoff volume generated from the net increase in impervious surfaces by a ten (10) year, twenty-four (24) hour storm shall be retained and infiltrated onsite [NJAC 7:50-6.84(a)6iii(1)].

▶ WHAT TO SUBMIT TO THE COMMISSION AND MUNICIPALITY:

NA A written description of the amount of pre-and post development impervious area as defined by Table 2-2a in TR-55 within each drainage area

along with a calculation of the required volume of stormwater that must be retained to meet this standard.

NA Volume tables for each stormwater management measure that includes the volume retained to the elevation of the lowest outlet.

NA Information which demonstrates compliance with volume infiltration and retention standard. The submitted report must demonstrate that the proposed retention/infiltration facilities can retain and infiltrate the volume generated from the net increase in impervious surfaces by a ten (10) year, twenty-four (24) hour storm.

---

**Item #3.** Stormwater infiltration facilities must be designed, constructed and maintained to provide a minimum separation of at least two (2) feet between the elevation of the lowest point of the bottom of the infiltration BMP and the seasonal high water table [NJAC 7:50-6.84(a)6iii(1)].

▶ WHAT TO SUBMIT TO THE COMMISSION AND MUNICIPALITY:

√ A plan depicting the location of all soil tests.

√ Soil log descriptions for the requisite number of test pits in the vicinity of the stormwater facilities in accordance with the following:

- a. A minimum of two (2) soil test pits must be excavated within the footprint of any proposed infiltration facility to determine the suitability and distribution of soil types present at the site.
- b. Placement of the test pits must be within twenty (20) feet of the facility perimeter, located along the longest axis bisecting the facility.
- c. For facilities larger than ten thousand (10,000) square feet in area, a minimum of one (1) additional soil test pit must be conducted within each additional area of ten thousand (10,000) square feet.
- d. The additional test pit(s) must be placed approximately equidistant to other test pits, so as to provide adequate characterization of the subsurface material.
- e. In all cases, where soil and/or groundwater properties vary significantly, additional test pits must be excavated in order to accurately characterize the subsurface conditions below the proposed infiltration facility.
- f. Soil test pits must extend to a minimum depth of eight (8) feet below the lowest elevation of the basin bottom or to a depth that is at least two (2) times the maximum potential water depth in the proposed infiltration facility, whichever is greater.
- g. A soil test pit log must be prepared for each soil test pit and provide the following:
  - provide the elevation of the existing ground surface;
  - the depth and thickness (in inches) of each soil horizon or substratum;

- the dominant matrix or background and mottle colors using the Munsell system of notation for hue, value and chroma;
  - the appropriate textural class as shown on the USDA textural triangle;
  - the volume percentage of coarse fragments (larger than two (2) millimeters in diameter);
  - the abundance, size, and contrast of mottles;
  - the soil structure, soil consistence, and soil moisture condition, using standard USDA classification terminology for each of these soil properties;
  - identify the presence of any soil horizon, substratum or other feature that exhibits an in-place permeability rate less than one (1) inch per hour;
  - the depth to seasonally high water level, either perched or regional; and
  - the static water level based upon the presence of soil mottles or other redoximorphic features, and elevation of observed seepage or saturation.
- 

**Item #4.** There will be no direct discharge of stormwater runoff from any point or nonpoint source to any wetland, wetland transition area (wetland buffer) or surface water body. In addition, stormwater runoff shall not be directed in such a way as to increase the volume and rate of discharge into any surface water body from that which existed prior to development of the parcel.

▶ WHAT TO SUBMIT:

NA A development plan depicting wetlands boundaries, wetlands transition areas (buffers) and surface water bodies, and the location of all discharges of stormwater runoff from structural facilities and non-structural stormwater management measures.

NA If there is an existing discharge to wetlands, provide calculations which demonstrate that the stormwater volume and rate of runoff will not increase after development.

---

**Item #5.** Stormwater infiltration facilities shall be sited in suitable soils verified by testing of undisturbed soil samples collected in the field, performed under direct supervision of a Professional Engineer, to meet the following [NJAC 7:50-6.84(a)6iv(2)]:

- I. To have permeability rates of between 1 and 20 inches per hour;
- II. A safety factor of two shall be applied to the design of the infiltration basin when performing any mounding (Item #7, below) and drain time analysis;
- III. The minimum acceptable “tested permeability rate” of any soil horizon or substratum shall be one (1) inch per hour. Soil materials that exhibit tested

permeability rates slower than one (1) inch per hour shall be considered unsuitable for stormwater infiltration. The maximum reportable “tested permeability rate” of any soil horizon or substratum shall be no greater than twenty (20) inches per hour regardless of the rate attained in the test procedure;

IV. If the maximum permeability rate of 20 inches per hour cannot be met but will be exceeded, stormwater must first be routed through a bioretention system prior to infiltration or soil replacement may be proposed; and

V. If the soils are slower than one (1) inch per hour and the soils cannot be replaced with suitable soils, the infiltration facility may be required to be relocated.

► WHAT TO SUBMIT TO THE COMMISSION AND MUNICIPALITY:

√ Results of permeability testing of undisturbed soil samples from the field taken below the bottom elevation of each stormwater management measure. Permeability tests must follow the methodologies outlined in the municipal land use ordinances.

√ A minimum of one (1) permeability test shall be performed at each soil test pit location. The soil permeability rate shall be determined using test methodology as prescribed in NJAC 7:9A-6.2 (Tube Permeameter Test), 6.5 (Pit Bailing Test) or 6.6 (Piezometer Test). When the tube permeameter test is used, a minimum of two replicate samples shall be taken and tested. Alternative permeability test procedures may be accepted by the approving authority provided the test procedure attains saturation of surrounding soils, accounts for hydraulic head effects on infiltration rates, provides a permeability rate with units expressed in inches per hour and is accompanied by a published source reference.

√ A plan containing cross section detail(s) of all stormwater BMPs alongside soil profile descriptions (to scale).

---

**Item #6.** The High Pollutant Loading Area (HPLA) standards apply where the proposed development includes areas that are defined as HPLAs in NJDEP stormwater regulations (NJAC 7:8-5.4(a)2iii(1)). HPLAs include areas in industrial and commercial development where solvents, and/or petroleum products are loaded, unloaded, stored or applied; areas where pesticides are loaded, unloaded, or stored; areas where hazardous materials are expected to be present in greater than ‘reportable quantities’ as defined by the USEPA at CFR 302.4; areas where recharge would be inconsistent with NJDEP approved remedial action work plan or landfill closure plan; areas of high risk for spills of toxic materials such as gas stations and vehicle maintenance facilities and areas of industrial stormwater exposed to “source material.”

Where stormwater runoff is exposed to high pollutant source material, the stormwater management plan shall demonstrate the following design criteria are met [NJAC 7:50-6.84(a)6iii(2)]:

**I.** The extent of the areas described as HPLAs have been minimized on the development site to the maximum extent practicable;

**II.** The stormwater runoff from the areas described as HPLAs are segregated to the maximum extent practicable from the stormwater runoff generated from the remainder of the site such that co-mingling of the stormwater runoff from the areas described as HPLAs and the remainder of the site will be minimized;

**III.** The amount of precipitation falling directly on the areas described as HPLAs are minimized to the maximum extent practicable by means of a canopy, roof or other similar structure that reduces the generation of stormwater runoff;

**IV.** The stormwater runoff from, or co-mingled with, the areas described as HPLAs for the Water Quality Design Storm, shall be subject to pretreatment by one or more of the following stormwater BMPs, designed in accordance with the New Jersey BMP Manual to provide 90 % TSS removal:

- a. Bioretention system;
  - b. Sand filter;
  - c. Wet ponds which shall be hydraulically disconnected by a minimum of 2 feet of vertical separation from the seasonal high water table and shall be designed to achieve a minimum 80% TSS removal rate;
  - d. Constructed stormwater wetlands; and/or
- c. Media filtration system manufactured treatment device with a minimum 80% TSS removal as verified by the New Jersey Corporation for Advanced Technology and as certified by NJDEP.

**V.** If the potential for contamination of stormwater runoff by petroleum products exists onsite, prior to being conveyed to the pretreatment BMP required in IV. above, the stormwater runoff from the areas described in I. and II. above shall be conveyed through an oil/grease separator or other equivalent manufactured filtering device to remove the petroleum hydrocarbons. The applicant must provide the Commission with sufficient data to demonstrate acceptable performance of the device.

► WHAT TO SUBMIT TO THE COMMISSION AND MUNICIPALITY:

NA A plan clearly identifying the areas on-site that are HPLAs.

NA A description in writing or on the plans that identifies the actions taken to minimize these areas.

NA Documentation that demonstrates how the stormwater from the HPLA on the site will meet the 90% TSS removal standard (refer to Item #10, below and Appendix 1).

---

**Item #7.** Groundwater mounds resulting from the infiltration of stormwater shall not cause stormwater or groundwater to breakout to the land surface or cause adverse impacts to adjacent water bodies, wetlands or subsurface structures including, but not limited to, basements and septic systems [NJAC 7:50-6.84(a)6iv(3)].



▶ AT A MINIMUM, SUBMIT THE FOLLOWING TO THE MUNICIPALITY:

√ A groundwater mounding analysis which considers the maximum design storm and, if the stormwater recharge facility is located near wetlands, the effects of any Radius of Influence (ROI) of the recharge facility on the wetlands. The analysis must provide specific conclusions as to whether each proposed recharge facility will cause stormwater or groundwater to breakout to the land surface or cause adverse impacts to adjacent water bodies, wetlands or subsurface structures including, but not limited to, basements and septic systems. The Professional Engineer's Groundwater Mounding Analysis Certification found in Appendix 2 may be utilized. Please note that if an applicant elects to submit the Certification, the municipality may require a more detailed analysis.

---

**Item #8.** To the maximum extent practical, stormwater management measures shall be designed to limit site disturbance, maximize stormwater management efficiencies, maintain or improve aesthetic conditions and incorporate pretreatment as a means of extending the functional life and increasing pollutant removal capacity of structural management facilities. The use of stormwater management measures that are using natural, non-wetland wooded depressions, or multiple infiltration facilities that are smaller in size, and distributed spatially throughout a parcel, rather than the use of a single larger structural stormwater management measure, shall be required to the maximum extent practical [NJAC 7:50-6.84(a)6iv(4)].

For all major development greater than one acre of disturbance or new impervious surface exceeding 1/4 acre, the following nine (9) nonstructural NJDEP BMPs for stormwater management must be addressed to the maximum extent practical [NJAC 7:8-5.3]:

- I. Protect areas that provide water quality benefits or areas particularly susceptible to erosion and sediment loss;
- II. Minimize impervious surfaces and break up or disconnect the flow of runoff over impervious surfaces;
- III. Maximize the protection of natural drainage features and vegetation;
- IV. Minimize the decrease in the pre-development time of concentration;
- V. Minimize land disturbance including clearing and grading;
- VI. Minimize soil compaction and all other soil disturbance;
- VII. Provide low-maintenance landscaping that provides for the retention and planting of native plants and minimizes the use of lawns, fertilizers and pesticides, in accordance with NJAC 7:50-6.24;
- VIII. Provide vegetated open-channel conveyance systems discharging into and through stable vegetated areas; and
- IX. Provide other source controls to prevent or minimize the use or exposure of pollutants at the site in order to prevent or minimize the release of those

pollutants into stormwater runoff. These source controls shall include, but are not limited to:

- a. Site design features that help to prevent accumulation of trash and debris in drainage systems;
- b. Site design features that help to prevent discharge of trash and debris from drainage systems;
- c. Site design features that help to prevent and/or contain spills or other harmful accumulations of pollutants at industrial or commercial developments; and
- d. Applying fertilizer in accordance with the requirements established under the Soil Erosion and Sediment Control Act, N.J.S.A. 4:24-39 et seq., and implementing rules, when establishing vegetation after land disturbance.

The NJDEP stormwater management rules require that any land area used as a nonstructural stormwater management measure shall be dedicated to a government agency, subjected to a conservation restriction filed with the appropriate County Clerk's office, or subject to an equivalent restriction that ensures that measure is maintained in perpetuity.

▶ WHAT TO SUBMIT TO THE COMMISSION AND MUNICIPALITY:

NA A description of the specific measures taken in the design of the site that limits site disturbance, maximizes stormwater management efficiencies, maintains or improves aesthetic conditions, incorporates pretreatment as a means of extending the functional life and increasing pollutant removal capacity of structural management facilities, uses natural non-wetland, wooded depressions or multiple infiltration facilities, and shows them distributed spatially throughout a parcel.

NA A written description of how the proposed development will incorporate the nine (9) nonstructural strategies (see above, I through IX) to the maximum extent practical. Alternatively, the following may be submitted:

NA The results of calculations utilizing the NJDEP's Non-Structural Point System (NSPS) spreadsheet that can be downloaded at [www.state.nj.us/dep/stormwater](http://www.state.nj.us/dep/stormwater) may be submitted. (*Note that this does not apply to linear development.*)

NA For linear development or development that does not "pass" the NSPS spreadsheet, a copy of the NJDEP's Low Impact Design (LID) Checklist may be submitted in an attempt to demonstrate whether the low impact design standards will be met to the maximum extent practical.

NA If the NJDEP point system does not show that the nine (9) non-structural strategies are being used sufficiently or if one or more of the nine (9) nonstructural strategies will not be implemented to the maximum extent practical, a detailed rationale must be provided in

writing which establishes a basis for the contention that maximal use of the strategy is not practicable on the site.

NA A plan which specifically identifies all proposed LID strategies including all areas of vegetated conveyance.

NA A description of how all non-structural strategies will be preserved and maintained in perpetuity pursuant to N.J.A.C. 7:8-5.3(c).

*Note: One of the techniques that has been advocated to meet the low impact stormwater design standards is to reduce the number of units. The Pinelands Commission does not advocate this approach.*

---

**Item #9.** There will be no direct discharge of stormwater to farmland to the maximum extent practical [NJAC 7:50-6.84(a)6ii(5)].

▶ AT A MINIMUM, SUBMIT THE FOLLOWING TO THE MUNICIPALITY:

NA A development plan which identifies any agricultural uses present on adjacent parcels, and includes the location of all discharges of stormwater runoff from structural facilities and non-structural measures. The plan must demonstrate that no direct discharge of stormwater is occurring onto farmland to the maximum extent practical.

---

**Item #10.** Stormwater management measures shall be designed to reduce the total suspended solids (TSS) load in the stormwater runoff from the post-developed site by eighty percent (80%) expressed as an annual average [NJAC 7:8-5.5].

▶ AT A MINIMUM, SUBMIT THE FOLLOWING TO THE MUNICIPALITY:

NA If NJDEP BMPs are utilized in the following calculations (“a” or “b”) for the accepted TSS removal, refer to Appendix 1 of this reference guide.

NA If the BMP measures utilized are not those noted in Appendix 1, refer to (c) below.

NA Total Suspended Solids (TSS) Reduction Calculations: Total Suspended Solids (TSS) Reduction Calculations for the parcel are to be completed as follows:

- a. If more than one stormwater BMP in series is necessary to achieve the required eighty percent (80%) TSS reduction for a site, the applicant shall utilize the following formula to calculate TSS reduction:

$R = A + B - (A \times B) / 100$ , where:

R = total TSS percent load removal from application of both BMPs;

A = the TSS percent removal rate applicable to the first BMP; and

B = the TSS percent removal rate applicable to the second BMP.

- b. If there is more than one onsite drainage area, the eighty percent (80%) TSS removal rate shall apply to each drainage area, unless the runoff from the subareas converge on site, in which case the removal rate can be demonstrated through a calculation using a weighted average.
- c. Alternative stormwater management measures, removal rates and methods of calculating removal rates may be used if the design engineer provides documentation acceptable to the municipality which demonstrates the suitability of these alternate measures, methods and rates. Any alternative stormwater management measure, removal rate or method of calculating the removal rate shall be subject to approval in writing by municipality and a copy shall be provided to the following:
  - The Division of Watershed Management, New Jersey Department of Environmental Protection, PO Box 418 Trenton, NJ, 08625-0418; and
  - The New Jersey Pinelands Commission, PO Box 7, New Lisbon, NJ, 08064.

---

**Item #11.** Stormwater management measures shall also be designed to reduce the nutrient load in the stormwater runoff from the post-developed site by the maximum extent practicable [NJAC 7:8-5.5(e)].

▶ AT A MINIMUM, SUBMIT THE FOLLOWING TO THE MUNICIPALITY:

NA A written description of how this standard will be met (refer to Table 4.2 in the NJDEP BMP Manual for guidance).

---

**Item #12.** Retain and recharge 100% of sites' average annual groundwater recharge volume [NJAC 7:8-5.4(a)2].

▶ AT A MINIMUM, SUBMIT THE FOLLOWING TO THE MUNICIPALITY:

NA One of the following must be provided:

- a. Calculations using the NJDEP Groundwater Recharge Spreadsheet (NJGRS), available in the NJ BMP Manual, Chapter 6 at [http://www.njstormwater.org/bmp\\_manual2.htm](http://www.njstormwater.org/bmp_manual2.htm);
- b. Calculations using the New Jersey Geological Survey Report GSR-32: A method for evaluating Groundwater Recharge Areas in New Jersey. Available at <http://www.njgeology.org/geodata/dgs99-2.htm>;
- c. Calculate and recharge the difference in runoff volume between 2 yr storms, pre and post development; and
- d. An alternate method, if approved by the municipal engineer.

**Item #13.** Stormwater management facility construction and as-built requirement standards [NJAC 7:50-6.84(a)6iv(5) and NJAC 7:50-6.84(a)6v].

▶ AT A MINIMUM, SUBMIT THE FOLLOWING TO THE MUNICIPALITY:

√ An plan with notes that pertain to the following:

- An as-built basin plan will be submitted to the municipal engineer;
- Specifically demonstrate how the proposed construction will conform with the construction measures outlined in the local land use ordinances and the CMP;
- Detail how the as-built basin permeability testing requirements will be met; and
- If the applicant proposes to utilize light grading equipment when grading lawn areas in order to help meet the low impact design standards of the local land use ordinances and the CMP, the plans must include a note stating so.

√ After construction, an as-built plan for all stormwater management facilities.

√ The results of replicate post-development field permeability tests taken within each constructed infiltration measure.

---

**Item #14.** Structural design standards. Stormwater management measures shall be designed as follows [NJAC 7:8-5.7]:

- I. The New Jersey Department of Environmental Protection's Best Management Practices (BMP) Manual shall be utilized for technical guidance;
- II. Stormwater management basins shall be designed with gently sloping sides. The maximum allowable basin side slope shall be three (3) horizontal to one (1) vertical (3:1);
- III. The establishment of attractive landscaping in and around the basin that mimics the existing vegetation and incorporates native Pinelands plants, including, but not limited to, the species listed in NJAC 7:50-6.25 and 6.26;
- IV. Stormwater infiltration BMPs, such as bioretention systems with infiltration, dry wells, infiltration basins, pervious paving systems with storage beds, and sand filters with infiltration, shall be designed, constructed and maintained to completely drain the total runoff volume generated by the basin's maximum design storm within seventy-two (72) hours after a storm event. Runoff storage for greater times can render the BMP ineffective and may result in anaerobic conditions, odor and both water quality and mosquito breeding problems; and
- V. To help ensure maintenance of the design permeability rate over time, a six (6) inch layer of K5 soil shall be placed on the bottom of a stormwater infiltration BMP. This soil layer shall meet the textural and permeability specifications of a K5 soil as provided at NJAC 7:9A, Appendix A, Figure 6, and be certified to meet these specifications by a Professional Engineer licensed

in the State of New Jersey. The depth to the seasonal high water table shall be measured from the bottom of the K5 sand layer.

▶ AT A MINIMUM, SUBMIT THE FOLLOWING TO THE MUNICIPALITY:

√ The plan must be designed in accordance with the above requirements.

---

**Item #15.** The following safety standards for structural stormwater management facilities and measures must be addressed [NJAC 7:8-6.2]:

**I.** If a structural stormwater management measure has an outlet structure, escape provisions shall be incorporated in or on the structure. Escape provisions include the permanent installation of ladders, steps, rungs, or other features that provide readily accessible means of ingress and egress from the outlet structure;

**II.** A trash rack is a device intended to intercept runoff-borne trash and debris that might otherwise block the hydraulic openings in an outlet structure of a structural stormwater management measure. Trash racks shall be installed upstream of such outlet structure openings as necessary to ensure proper functioning of the structural stormwater management measure in accordance with the following:

- a. The trash rack should be constructed primarily of bars aligned in the direction of flow with one (1) inch spacing between the bars to the elevation of the water quality design storm. For elevations higher than the water quality design storm, the bars shall be spaced no greater than one-third (1/3) the width of the hydraulic opening it is protecting or six inches, whichever is less. Transverse bars aligned perpendicular to flow should be sized and spaced as necessary for rack stability and strength;
- b. The trash rack shall not adversely affect the hydraulic performance of either the outlet structure opening it is protecting or the overall outlet structure;
- c. The trash rack shall have sufficient net open area under clean conditions to limit the peak design storm velocity through it to a maximum of 2.5 feet per second; and
- d. The trash rack shall be constructed and installed to be rigid, durable, and corrosion resistant, and shall be designed to withstand a perpendicular live loading of 300 pounds per square foot.

**III.** An overflow grate is a device intended to protect the opening in the top of a stormwater management measure outlet structure. If an outlet structure has an overflow grate, such grate shall meet the following requirements:

- a. The overflow grate spacing shall be no more than two (2) inches across the smallest dimension; and
- b. The overflow grate shall be constructed and installed to be rigid, durable, and corrosion resistant, and shall be designed to

withstand a perpendicular live loading of three hundred (300) pounds per square foot.

IV. The maximum side slope for an earthen dam, embankment, or berm shall not be steeper than three (3) horizontal to one (1) vertical (3:1); and

V. Safety ledges shall be constructed on the slopes of all new structural stormwater management measures having a permanent pool of water deeper than two and one-half (2.5) feet. Such safety ledges shall be comprised of two steps. Each step shall be four (4) to six (6) feet in width. One step shall be located approximately two and one-half (2 1/2) feet below the permanent water surface, and the second step shall be located one (1) to one and one-half (1 1/2) feet above the permanent water surface.

▶ AT A MINIMUM, SUBMIT THE FOLLOWING TO THE MUNICIPALITY:

NA The plan must be designed in accordance with NJAC 7:8-6.2.

---

**Item #16.** The General Inspection, Maintenance and Repair Plan shall contain the following [NJAC 7:50-6.84(a)6vii]:

- I. Accurate and comprehensive drawings of the site's stormwater management measures;
- II. Specific locations of each stormwater management measure identified by means of longitude and latitude as well as block and lot number;
- III. Specific preventative and corrective maintenance tasks and schedules for such tasks for each stormwater BMP;
- IV. Cost estimates, including estimated cost of sediment, debris or trash removal;
- V. The name, address and telephone number of the person or persons responsible for regular inspections and preventative and corrective maintenance including repair and replacement;
- VI. Reporting records for maintenance;
- VII. A description of the financing that will ensure the inspection, maintenance and repair of all stormwater management BMPs;
- VIII. The plan must address existing tree and vegetation protection during construction;
- IX. A statement that an inspection, maintenance and repair report will be updated and submitted annually to the municipality;
- X. A description of all preservation measures and maintenance procedures for all non-structural stormwater management measures; and
- XI. A description of all stormwater management measure easements designed to facilitate inspections and maintenance as necessary.

Nonstructural stormwater management strategies protection - The local land use ordinances and the CMP provide that development be designed to meet the nonstructural stormwater management strategy standards of N.J.A.C. 7:8-5.3. These standards require

that any land area used as a nonstructural stormwater management measure shall be dedicated to a government agency, subjected to a conservation restriction filed with the appropriate County Clerk's office, or equivalent restriction that ensures that measure is maintained in perpetuity. Any maintenance plan must specify which of these methods will be employed, and how the protection will be implemented [NJAC 7:8-5.3(c)].

Maintenance requirements - The NJDEP regulations provide that the responsibility for maintenance of stormwater management measures shall not be assigned or transferred to the owner or tenant of an individual property in a residential development or project, unless such owner or tenant owns or leases the entire residential development or project [NJAC 7:8-5.8].

▶ AT A MINIMUM, SUBMIT THE FOLLOWING TO THE MUNICIPALITY:

√ A maintenance plan that contains all of the above required information.

NA Copies of all proposed deed restrictions for any land area used as a nonstructural stormwater management measure.

NA Copies of all proposed easements.

---



## APPENDIX B: DRAWINGS

### DRAWINGS

|          |  |
|----------|--|
| FIGURE A | SITE LAYOUT PLAN                       |
| FIGURE B | CRUSHED STONE INFILTRATION AREA DETAIL |
| FIGURE C | MISCELLANEOUS DETAILS PLAN             |

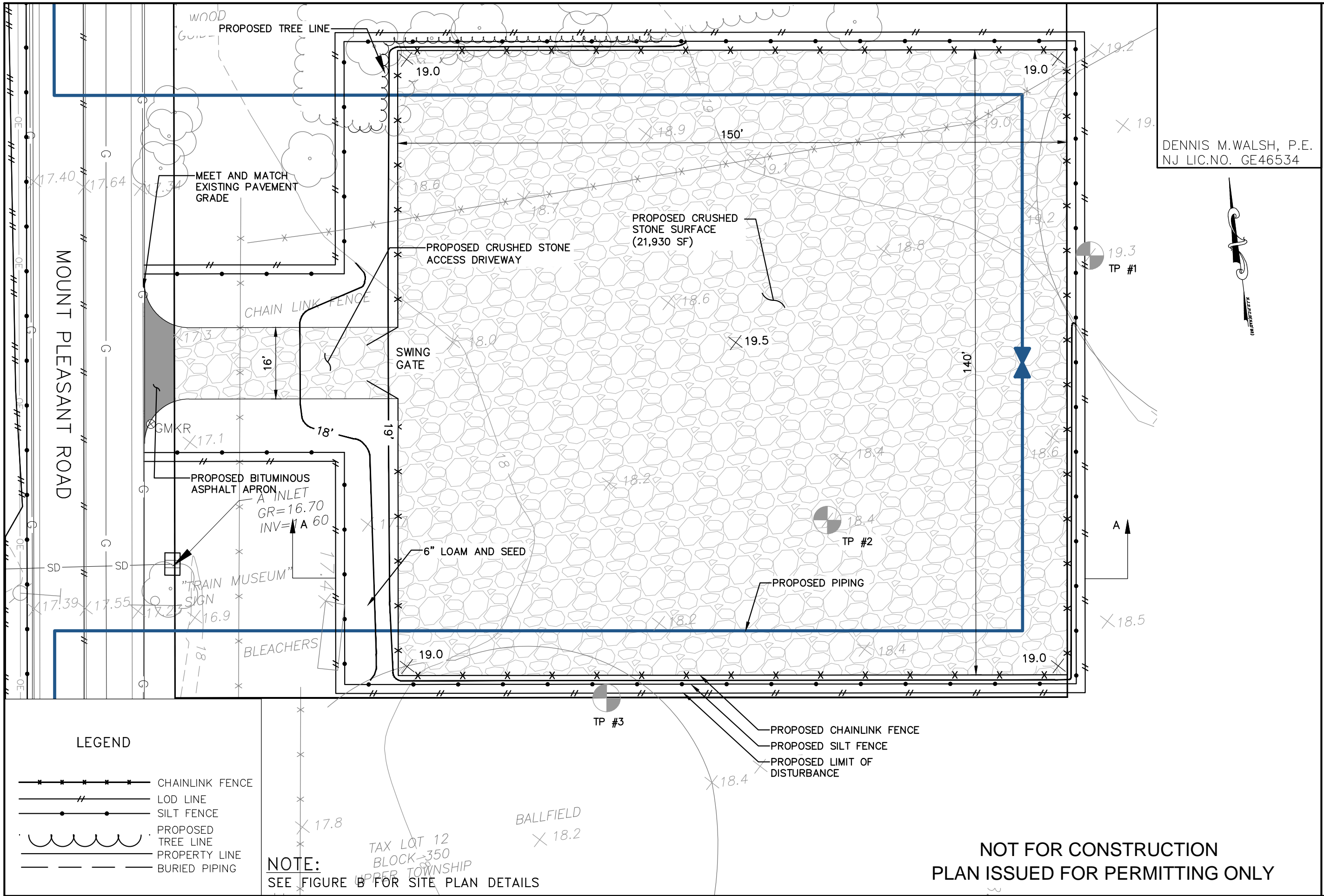

**LEGEND**

- x — x — x — x — CHAINLINK FENCE
- # — LOD LINE
- • — SILT FENCE
- ~ — PROPOSED TREE LINE
- — — PROPERTY LINE
- - - - BURIED PIPING

**NOTE:**  
SEE FIGURE B FOR SITE PLAN DETAILS

**INTERCONNECT STATION  
SITE PLAN**

DESIGNED BY: LS, JG  
CHECKED BY: DW  
DRAWN BY: GA, PJ, PM  
225616 FIGURE A.DWG

SOUTH JERSEY GAS  
1 SOUTH JERSEY PLAZA  
FOLSOM, NJ 08037

PROPOSED 24" NATURAL GAS PIPELINE  
FOR SYSTEM REINFORCEMENT AND TO  
SUPPLY B.I. ENGLAND POWER PLANT

JOB NO: 225616  
DATE: MAY 2014  
SCALE: 1"=20'

FIGURE A

DENNIS M. WALSH, P.E.  
NJ LIC. NO. GE46534

50 Millstone Road, Building 300  
East Windsor, New Jersey 08520  
877.766.8881 | www.woodardcurran.com

**WOODARD  
& CURRAN**

COMMITMENT & INTEGRITY DRIVE RESULTS

225616 FIGURE A.dwg

**NOT FOR CONSTRUCTION  
PLAN ISSUED FOR PERMITTING ONLY**

DENNIS M. WALSH, P.E.  
 NJ LIC.NO. GE46534

50 Millstone Road, Building 300  
 East Windsor, New Jersey 08520  
 877.786.8881 | www.woodardcurran.com  
 COMMITMENT & INTEGRITY DRIVE RESULTS

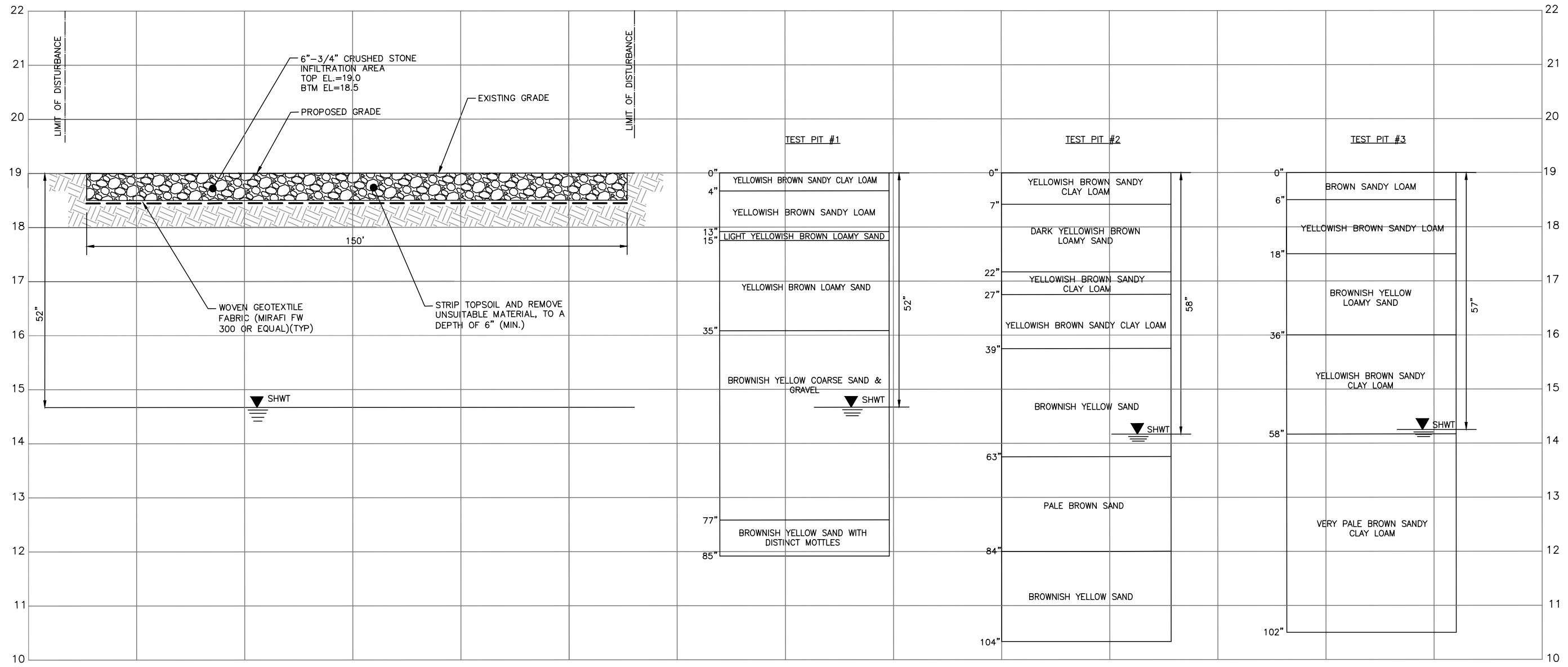

**SECTION A-A CRUSHED STONE INFILTRATION AREA DETAIL**

SCALE: HORIZ: 1" = 30'  
 VERT: 1" = 2'

INTERCONNECT STATION  
 CROSS SECTION A-A  
 UPPER TOWNSHIP  
 UPPER CAPE MAY COUNTY

SOUTH JERSEY GAS  
 1 SOUTH JERSEY PLAZA  
 FOLSOM, NJ 08037  
 PROPOSED 24" NATURAL GAS PIPELINE  
 FOR SYSTEM REINFORCEMENT AND TO  
 SUPPLY B.L ENGLAND POWER PLANT

JOB NO: 225616  
 DATE: OCTOBER 2014  
 SCALE: AS SHOWN

FIGURE B

PLAN ISSUED FOR PERMITTING ONLY

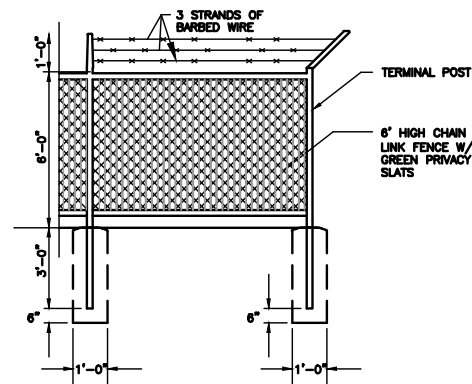

**TYPICAL CHAIN LINK FENCE**  
N.T.S.

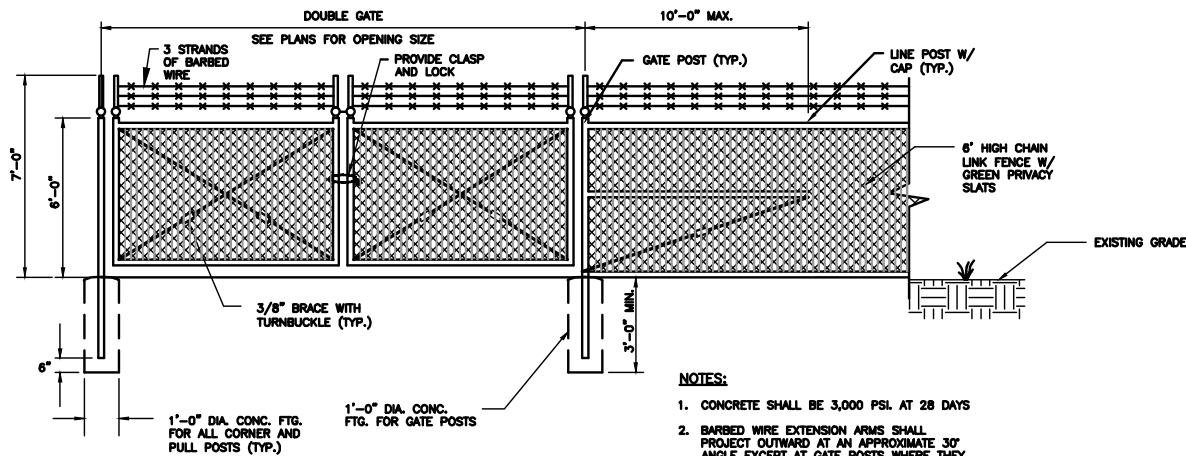

**TYPICAL CHAIN LINK FENCE AND GATE**  
N.T.S.

- NOTES:**
1. CONCRETE SHALL BE 3,000 PSI. AT 28 DAYS
  2. BARBED WIRE EXTENSION ARMS SHALL PROJECT OUTWARD AT AN APPROXIMATE 30° ANGLE EXCEPT AT GATE POSTS WHERE THEY WILL BE VERTICAL.

DENNIS M. WALSH, P.E.  
NJ LIC. NO. GE46534

50 Millstone Road, Building 300  
East Windsor, New Jersey 08520  
877.786.8881 | www.woodardcurran.com



COMMITMENT & INTEGRITY DRIVE RESULTS

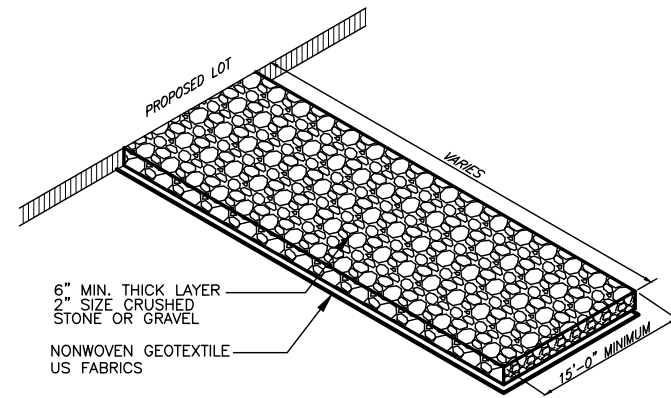

- NOTE:**
1. CONSTRUCTION ENTRANCE SHALL BE INSTALLED AT ALL CONSTRUCTION ENTRANCE LOCATIONS.
  2. UPON COMPLETION OF CONSTRUCTION ACTIVITIES, THE CONTRACTOR SHALL REMOVE CONSTRUCTION ENTRANCES AND REPLACE WITH 6" OF 3/4" CRUSHED STONE TO THE LOCATION SHOWN ON DRAWING C-200

**TEMPORARY CONSTRUCTION ENTRANCE**

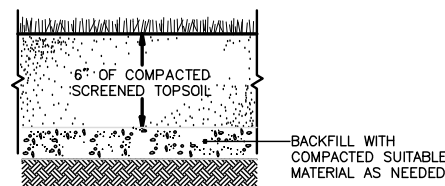

**LOAM AND SEED DETAIL**  
N.T.S.

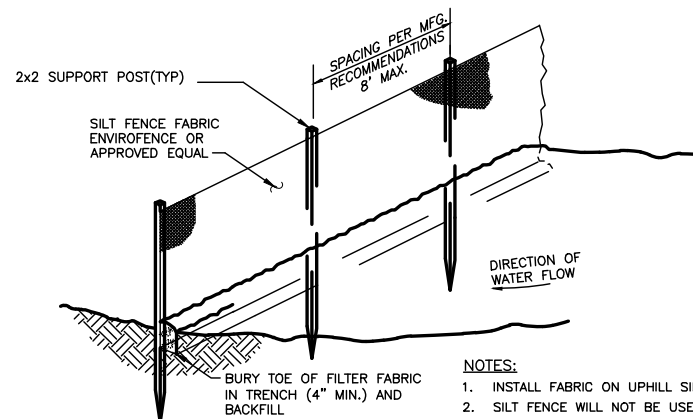

**SILTATION FENCE DETAIL**  
N.T.S.

- NOTES:**
1. INSTALL FABRIC ON UPHILL SIDE OF SUPPORT POSTS.
  2. SILT FENCE WILL NOT BE USED IN DRAINAGE WAYS.
  3. CONTRACTOR TO REMOVE SEDIMENT AS NECESSARY TO MAINTAIN FABRIC EFFECTIVENESS.

**SOIL EROSION AND SEDIMENTATION CONTROL NOTES:**

1. PRIOR TO STARTING ANY OTHER WORK ON THE SITE, THE CONTRACTOR SHALL INSTALL EROSION CONTROL MEASURES AS SHOWN ON THE CONTRACT DOCUMENTS AND AS IDENTIFIED IN FEDERAL, STATE, AND LOCAL APPROVAL DOCUMENTS PERTAINING TO THIS PROJECT.
2. CONTRACTOR SHALL INSPECT AND MAINTAIN EROSION CONTROL MEASURES DAILY, REMOVE SEDIMENT THEREFROM ON A WEEKLY BASIS AND WITHIN TWELVE HOURS AFTER EACH STORM EVENT, AND DISPOSE OF SEDIMENTS IN AN UPLAND AREA SUCH THAT THEY DO NOT ENCUMBER OTHER DRAINAGE STRUCTURES AND PROTECTED AREAS.
4. CONTRACTOR SHALL BE FULLY RESPONSIBLE TO CONTROL CONSTRUCTION SUCH THAT SEDIMENTATION SHALL NOT AFFECT REGULATORY PROTECTED AREAS, WHETHER SUCH SEDIMENTATION IS CAUSED BY WATER, WIND, OR DIRECT DEPOSIT.
5. CONTRACTOR SHALL PERFORM CONSTRUCTION SEQUENCING SUCH THAT EARTH MATERIALS ARE EXPOSED FOR A MINIMUM TIME BEFORE THEY ARE COVERED, SEEDED, OR OTHERWISE STABILIZED TO PREVENT EROSION.
8. IT SHALL BE THE CONTRACTOR'S RESPONSIBILITY TO CONTROL DUST AND TAKE ALL NECESSARY MEASURES TO ENSURE ALL ROADS ARE MAINTAINED IN A DUST FREE CONDITION AT ALL TIMES THROUGHOUT THE LIFE OF THE CONTRACT. REPETITIVE TREATMENTS SHOULD BE APPLIED AS NECESSARY.
9. PERMANENT VEGETATIVE COVER SHALL BE INSTALLED TO ALL DISTURBED AREAS THAT HAVE REACHED FINISH GRADE AS SOON AS POSSIBLE, BUT NOT MORE THAN FOURTEEN (14) DAYS AFTER THE CONSTRUCTION ACTIVITY IN ANY GIVEN AREA HAS PERMANENTLY CEASED. THE RECOMMENDED PERMANENT SEEDING DATES ARE APRIL 1 TO JUNE 15 AND AUGUST 15 TO OCTOBER 1.
10. TEMPORARY VEGETATIVE COVER SHALL BE APPLIED TO ANY DISTURBED AREAS (INCLUDING SOIL STOCKPILE AREAS) THAT HAVE NOT YET REACHED FINISHED GRADE AS SOON AS POSSIBLE AFTER THE CONSTRUCTION ACTIVITY IN THAT AREA HAS TEMPORARILY CEASED, UNLESS THE ACTIVITY IS TO RESUME WITHIN FIVE (5) DAYS. THE RECOMMENDED TEMPORARY SEEDING DATES ARE MARCH 1 TO JUNE 15 AND AUGUST 15 TO OCTOBER 1.
11. AREAS WHICH HAVE BEEN TEMPORARILY OR PERMANENTLY SEEDED SHOULD BE MULCHED IMMEDIATELY FOLLOWING SEEDING IN ADDITION TO AREAS WHICH CANNOT BE SEEDED WITHIN THE RECOMMENDED SEEDING DATES AND ANY SOIL STOCKPILE AREAS. TEMPORARY MULCHING SHOULD BE PERFORMED AS SOON AS POSSIBLE AFTER THE CONSTRUCTION ACTIVITY IN THAT AREA HAS TEMPORARILY CEASED UNLESS THE ACTIVITY IS TO RESUME WITHIN FIVE (5) DAYS. STRAW OR HAY MULCH, WOOD FIBER MULCH, AND HYDROMULCH ARE RECOMMENDED.

12. ALL MULCHES MUST BE INSPECTED PERIODICALLY, IN PARTICULAR AFTER RAINSTORMS, TO CHECK FOR RILL EROSION. WHERE EROSION IS OBSERVED, ADDITIONAL MULCH MUST BE APPLIED. IF NETTING IS USED, THE NET SHOULD BE INSPECTED AFTER RAINSTORMS FOR DISLOCATION OR FAILURE. IF WASHOUTS OR BREAKAGE OCCUR, THE NET MUST BE REINSTALLED AS NECESSARY AFTER REPAIRING DAMAGE TO SLOPE. INSPECTIONS SHOULD TAKE PLACE UNTIL GRASSES ARE FIRMLY ESTABLISHED. GRASS IS CONSIDERED TO BE FIRMLY ESTABLISHED AT A MINIMUM HEIGHT OF THREE (3) INCHES. ANY EXISTING OR PROPOSED CATCH BASINS THAT MAY BE SUBJECT TO SEDIMENTATION PROCESSES SHALL HAVE SILT SACKS INSTALLED TO PREVENT SEDIMENT FROM ENTERING THE PROPOSED STORM DRAINAGE SYSTEM PRIOR TO PERMANENT STABILIZATION OF THE DISTURBED SITE. THE PROPER INLET PROTECTION DEVICES SHALL BE INSTALLED WHERE STORM DRAIN INLETS ARE TO BE MADE OPERATIONAL BEFORE PERMANENT STABILIZATION OF ANY DISTURBED DRAINAGE AREA.
  13. THE CONTRACTOR SHALL RESTORE DISTURBED AREAS AS CLOSELY AS POSSIBLE. AREAS DAMAGED DURING CONSTRUCTION SHALL BE RESODDED, RESEEDED, OR OTHERWISE RESTORED TO THEIR ORIGINAL STATE. TREES AND OTHER EXISTING VEGETATION SHALL BE RETAINED WHEREVER FEASIBLE.
- CONTRACTOR SHALL PREVENT DUST, SEDIMENT, AND DEBRIS FROM EXITING THE SITE AND SHALL BE RESPONSIBLE FOR CLEANUP, REPAIRS AND CORRECTIVE ACTION IF SUCH OCCURS.

**SEQUENCE OF CONSTRUCTION NOTE:**

1. CONSTRUCTION ACTIVITIES WILL INCLUDE CLEARING AND GRUBBING, EARTHWORK, UTILITY INSTALLATION, AND EROSION/SEDIMENT CONTROL INSTALLATION AND MAINTENANCE. IN GENERAL, THE SEQUENCE OF CONSTRUCTION WILL BE AS FOLLOWS:
  - A. INSTALLATION OF EROSION CONTROLS; INCLUDING SILT FENCE AND CONSTRUCTION ENTRANCE.
  - B. CLEARING AND GRUBBING OF SITE
  - C. ROUGH GRADING OF SITE
  - D. UTILITY INSTALLATION
  - E. FINE GRADING OF SITE
  - F. INSTALLATION OF GROUND COVER TREATMENT/STABILIZATION
  - G. INSTALLATION OF FENCING AND GATE

**AS-BUILT REQUIREMENT NOTE:**

1. UPON COMPLETION OF CONSTRUCTION THE CONTRACTOR SHALL BE RESPONSIBLE TO PROVIDE THE PINELANDS COMMISSION WITH A RECORD PLAN OF ACTUAL CONSTRUCTION IN ACCORDANCE WITH ITEM NO. 13 OF THE PINELANDS STORMWATER CHECKLIST.
2. PRIOR TO CRUSHED STONE INSTALLATION, THE CONTRACTOR SHALL BE RESPONSIBLE TO PERFORM A FIELD PERMEABILITY TEST WITHIN THE CRUSHED STONE AREA TO VERIFY DESIGN PERMEABILITY RATES.

INTERCONNECT STATION  
SITE DETAILS  
UPPER TOWNSHIP  
UPPER CAPE MAY COUNTY

SOUTH JERSEY GAS  
1 SOUTH JERSEY PLAZA  
FOLSOM, NJ 08037



PROPOSED 24" NATURAL GAS PIPELINE  
FOR SYSTEM REINFORCEMENT AND TO  
SUPPLY B.L. ENGLAND POWER PLANT

DESIGNED BY: PJJ  
DRAWN BY: PMM  
CHECKED BY: PJJ  
225616 FIGURE C.DWG

JOB NO: 225616  
DATE: MAY 2014  
SCALE: AS SHOWN

FIGURE C

PLAN ISSUED FOR PERMITTING ONLY

## APPENDIX C: TEST PIT DATA AND SOILS INFORMATION

Soil Map—Cape May County, New Jersey



Map Scale: 1:675 if printed on A landscape (11" x 8.5") sheet.

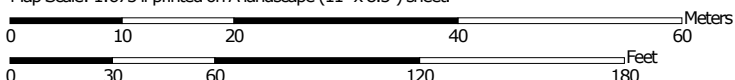

Map projection: Web Mercator Corner coordinates: WGS84 Edge tics: UTM Zone 18N WGS84



## MAP LEGEND

### Area of Interest (AOI)

 Area of Interest (AOI)

### Soils

 Soil Map Unit Polygons

 Soil Map Unit Lines

 Soil Map Unit Points

### Special Point Features



Blowout



Borrow Pit



Clay Spot



Closed Depression



Gravel Pit



Gravelly Spot



Landfill



Lava Flow



Marsh or swamp



Mine or Quarry



Miscellaneous Water



Perennial Water



Rock Outcrop



Saline Spot



Sandy Spot



Severely Eroded Spot



Sinkhole



Slide or Slip



Sodic Spot



Spoil Area



Stony Spot



Very Stony Spot



Wet Spot



Other



Special Line Features

### Water Features



Streams and Canals

### Transportation



Rails



Interstate Highways



US Routes



Major Roads



Local Roads

### Background



Aerial Photography

## MAP INFORMATION

The soil surveys that comprise your AOI were mapped at 1:24,000.

Warning: Soil Map may not be valid at this scale.

Enlargement of maps beyond the scale of mapping can cause misunderstanding of the detail of mapping and accuracy of soil line placement. The maps do not show the small areas of contrasting soils that could have been shown at a more detailed scale.

Please rely on the bar scale on each map sheet for map measurements.

Source of Map: Natural Resources Conservation Service  
 Web Soil Survey URL: <http://websoilsurvey.nrcs.usda.gov>  
 Coordinate System: Web Mercator (EPSG:3857)

Maps from the Web Soil Survey are based on the Web Mercator projection, which preserves direction and shape but distorts distance and area. A projection that preserves area, such as the Albers equal-area conic projection, should be used if more accurate calculations of distance or area are required.

This product is generated from the USDA-NRCS certified data as of the version date(s) listed below.

Soil Survey Area: Cape May County, New Jersey  
 Survey Area Data: Version 9, Dec 19, 2013

Soil map units are labeled (as space allows) for map scales 1:50,000 or larger.

Date(s) aerial images were photographed: Mar 19, 2011—May 7, 2011

The orthophoto or other base map on which the soil lines were compiled and digitized probably differs from the background imagery displayed on these maps. As a result, some minor shifting of map unit boundaries may be evident.

## Map Unit Legend

| Cape May County, New Jersey (NJ009) |  |              |                |
|-------------------------------------|--|--------------|----------------|
| Map Unit Symbol                     | Map Unit Name  | Acres in AOI | Percent of AOI |
| BEXAS                               | Berryland and Mullica soils, 0 to 2 percent slopes, occasionally flooded | 0.0          | 2.4%           |
| HbmB                                | Hammonton loamy sand, 0 to 5 percent slopes                              | 1.6          | 97.6%          |
| <b>Totals for Area of Interest</b>  |  | <b>1.6</b>   | <b>100.0%</b>  |



## Map Unit Description

The map units delineated on the detailed soil maps in a soil survey represent the soils or miscellaneous areas in the survey area. The map unit descriptions in this report, along with the maps, can be used to determine the composition and properties of a unit.

A map unit delineation on a soil map represents an area dominated by one or more major kinds of soil or miscellaneous areas. A map unit is identified and named according to the taxonomic classification of the dominant soils. Within a taxonomic class there are precisely defined limits for the properties of the soils. On the landscape, however, the soils are natural phenomena, and they have the characteristic variability of all natural phenomena. Thus, the range of some observed properties may extend beyond the limits defined for a taxonomic class. Areas of soils of a single taxonomic class rarely, if ever, can be mapped without including areas of other taxonomic classes. Consequently, every map unit is made up of the soils or miscellaneous areas for which it is named and some minor components that belong to taxonomic classes other than those of the major soils.

Most minor soils have properties similar to those of the dominant soil or soils in the map unit, and thus they do not affect use and management. These are called noncontrasting, or similar, components. They may or may not be mentioned in a particular map unit description. Other minor components, however, have properties and behavioral characteristics divergent enough to affect use or to require different management. These are called contrasting, or dissimilar, components. They generally are in small areas and could not be mapped separately because of the scale used. Some small areas of strongly contrasting soils or miscellaneous areas are identified by a special symbol on the maps. If included in the database for a given area, the contrasting minor components are identified in the map unit descriptions along with some characteristics of each. A few areas of minor components may not have been observed, and consequently they are not mentioned in the descriptions, especially where the pattern was so complex that it was impractical to make enough observations to identify all the soils and miscellaneous areas on the landscape.

The presence of minor components in a map unit in no way diminishes the usefulness or accuracy of the data. The objective of mapping is not to delineate pure taxonomic classes but rather to separate the landscape into landforms or landform segments that have similar use and management requirements. The delineation of such segments on the map provides sufficient information for the development of resource plans. If intensive use of small areas is planned, however, onsite investigation is needed to define and locate the soils and miscellaneous areas.

An identifying symbol precedes the map unit name in the map unit descriptions. Each description includes general facts about the unit and gives important soil properties and qualities.

Soils that have profiles that are almost alike make up a *soil series*. All the soils of a series have major horizons that are similar in composition, thickness, and arrangement. Soils of a given series can differ in texture of the surface layer, slope, stoniness, salinity, degree of erosion, and other characteristics that affect their use. On the basis of such differences, a soil series is divided into *soil phases*. Most of the areas shown on the detailed soil maps are phases of soil series. The name of a soil phase commonly indicates a feature that affects use or management. For example, Alpha silt loam, 0 to 2 percent slopes, is a phase of the Alpha series.

Some map units are made up of two or more major soils or miscellaneous areas. These map units are complexes, associations, or undifferentiated groups.

A *complex* consists of two or more soils or miscellaneous areas in such an intricate pattern or in such small areas that they cannot be shown separately on the maps. The pattern and proportion of the soils or miscellaneous areas are somewhat similar in all areas. Alpha-Beta complex, 0 to 6 percent slopes, is an example.

An *association* is made up of two or more geographically associated soils or miscellaneous areas that are shown as one unit on the maps. Because of present or anticipated uses of the map units in the survey area, it was not considered practical or necessary to map the soils or miscellaneous areas separately. The pattern and relative proportion of the soils or miscellaneous areas are somewhat similar. Alpha-Beta association, 0 to 2 percent slopes, is an example.

An *undifferentiated group* is made up of two or more soils or miscellaneous areas that could be mapped individually but are mapped as one unit because similar interpretations can be made for use and management. The pattern and proportion of the soils or miscellaneous areas in a mapped area are not uniform. An area can be made up of only one of the major soils or miscellaneous areas, or it can be made up of all of them. Alpha and Beta soils, 0 to 2 percent slopes, is an example.

Some surveys include *miscellaneous areas*. Such areas have little or no soil material and support little or no vegetation. Rock outcrop is an example.

Additional information about the map units described in this report is available in other soil reports, which give properties of the soils and the limitations, capabilities, and potentials for many uses. Also, the narratives that accompany the soil reports define some of the properties included in the map unit descriptions.

## Report—Map Unit Description

### Cape May County, New Jersey

#### **BEXAS—Berryland and Mullica soils, 0 to 2 percent slopes, occasionally flooded**

##### **Map Unit Setting**

*Elevation:* 0 to 140 feet

*Mean annual precipitation:* 28 to 59 inches

*Mean annual air temperature:* 46 to 79 degrees F

*Frost-free period:* 161 to 231 days

### Map Unit Composition

*Berryland, occasionally flooded, and similar soils: 50 percent*

*Mullica, occasionally flooded, and similar soils: 40 percent*

*Minor components: 10 percent*

### Description of Berryland, Occasionally Flooded

#### Setting

*Landform: Depressions, flats, drainageways*

*Landform position (two-dimensional): Toeslope*

*Landform position (three-dimensional): Base slope*

*Down-slope shape: Concave, linear*

*Across-slope shape: Concave*

*Parent material: Sandy fluviomarine deposits*

#### Properties and qualities

*Slope: 0 to 2 percent*

*Depth to restrictive feature: More than 80 inches*

*Drainage class: Very poorly drained*

*Capacity of the most limiting layer to transmit water (Ksat): High to very high (2.00 to 20.00 in/hr)*

*Depth to water table: About 0 to 6 inches*

*Frequency of flooding: Occasional*

*Frequency of ponding: Occasional*

*Available water capacity: Low (about 3.7 inches)*

#### Interpretive groups

*Farmland classification: Farmland of unique importance*

*Land capability (nonirrigated): 5w*

*Hydrologic Soil Group: B/D*

#### Typical profile

*0 to 11 inches: Sand*

*11 to 19 inches: Sand*

*19 to 32 inches: Sand*

*32 to 40 inches: Sand*

*40 to 44 inches: Sand*

*44 to 80 inches: Stratified sand to sandy loam*

### Description of Mullica, Occasionally Flooded

#### Setting

*Landform: Depressions, flood plains, drainageways*

*Landform position (two-dimensional): Toeslope*

*Landform position (three-dimensional): Base slope*

*Down-slope shape: Concave, linear*

*Across-slope shape: Concave, linear*

*Parent material: Sandy fluviomarine deposits and/or loamy fluviomarine deposits*

#### Properties and qualities

*Slope: 0 to 2 percent*

*Depth to restrictive feature: More than 80 inches*

*Drainage class:* Very poorly drained  
*Capacity of the most limiting layer to transmit water (Ksat):* Moderately high to high (0.60 to 5.95 in/hr)  
*Depth to water table:* About 0 to 6 inches  
*Frequency of flooding:* Occasional  
*Frequency of ponding:* Occasional  
*Available water capacity:* Moderate (about 6.0 inches)

**Interpretive groups**

*Farmland classification:* Farmland of unique importance  
*Land capability (nonirrigated):* 4w  
*Hydrologic Soil Group:* D

**Typical profile**

*0 to 2 inches:* Mucky peat  
*2 to 9 inches:* Sandy loam  
*9 to 14 inches:* Sandy loam  
*14 to 28 inches:* Sandy loam  
*28 to 31 inches:* Loamy sand  
*31 to 40 inches:* Sand  
*40 to 80 inches:* Gravelly loamy sand

**Minor Components**

**Manahawkin, frequently flooded**

*Percent of map unit:* 5 percent  
*Landform:* Flood plains  
*Down-slope shape:* Linear  
*Across-slope shape:* Linear

**Atsion**

*Percent of map unit:* 5 percent  
*Landform:* Flats  
*Landform position (two-dimensional):* Footslope  
*Landform position (three-dimensional):* Dip, talf  
*Down-slope shape:* Linear  
*Across-slope shape:* Linear

**HbmB—Hammonton loamy sand, 0 to 5 percent slopes**

**Map Unit Setting**

*Elevation:* 0 to 120 feet  
*Mean annual precipitation:* 28 to 59 inches  
*Mean annual air temperature:* 46 to 79 degrees F  
*Frost-free period:* 161 to 231 days

**Map Unit Composition**

*Hammonton and similar soils:* 80 percent  
*Minor components:* 20 percent

## Description of Hammonton

### Setting

*Landform:* Depressions, flats  
*Landform position (two-dimensional):* Toeslope  
*Landform position (three-dimensional):* Base slope  
*Down-slope shape:* Concave, linear  
*Across-slope shape:* Concave, linear  
*Parent material:* Coarse-loamy fluviomarine deposits

### Properties and qualities

*Slope:* 0 to 5 percent  
*Depth to restrictive feature:* More than 80 inches  
*Drainage class:* Moderately well drained  
*Capacity of the most limiting layer to transmit water (Ksat):* High (2.00 to 6.00 in/hr)  
*Depth to water table:* About 18 to 42 inches  
*Frequency of flooding:* None  
*Frequency of ponding:* None  
*Available water capacity:* Moderate (about 6.9 inches)

### Interpretive groups

*Farmland classification:* Farmland of statewide importance  
*Land capability (nonirrigated):* 2w  
*Hydrologic Soil Group:* B

### Typical profile

*0 to 8 inches:* Loamy sand  
*8 to 18 inches:* Loamy sand  
*18 to 36 inches:* Sandy loam  
*36 to 80 inches:* Sand

## Minor Components

### Fallsington

*Percent of map unit:* 5 percent  
*Landform:* Depressions, flats  
*Landform position (two-dimensional):* Toeslope  
*Landform position (three-dimensional):* Base slope  
*Down-slope shape:* Concave, linear  
*Across-slope shape:* Concave, linear

### Glassboro

*Percent of map unit:* 5 percent  
*Landform:* Flats, drainageways  
*Landform position (two-dimensional):* Toeslope  
*Landform position (three-dimensional):* Base slope  
*Down-slope shape:* Linear  
*Across-slope shape:* Linear, concave

### Mullica, rarely flooded

*Percent of map unit:* 5 percent  
*Landform:* Depressions, flood plains, drainageways  
*Landform position (two-dimensional):* Toeslope

*Landform position (three-dimensional):* Base slope  
*Down-slope shape:* Concave, linear  
*Across-slope shape:* Concave, linear

**Atsion**

*Percent of map unit:* 5 percent  
*Landform:* Depressions  
*Landform position (two-dimensional):* Toeslope  
*Landform position (three-dimensional):* Base slope  
*Down-slope shape:* Concave  
*Across-slope shape:* Concave

**Data Source Information**

Soil Survey Area: Cape May County, New Jersey  
Survey Area Data: Version 9, Dec 19, 2013

## SOILS DATA SHEET

Project Number: 225616  
 Project Name: South Jersey Gas 24" Gas Line  
 Sample Pit #1

Logged by: Steven Ewing  
 Date: 3/21/2014

| Horizon Depth<br>(inches) | Horizon Description   | Vol. % of<br>Coarse Fragmts | Structure | Consistence | Moisture | Soil Test ID |
|---------------------------|---|-----------------------------|-----------|-------------|----------|--------------|
| 0-4                       | Yellowish Brown 10YR5/8 Sandy Clay Loam                           | 0                           | SGR       | S           | NF       |              |
| 4-13                      | Yellowish Brown 10YR 5/4 Sandy Loam                               | 0                           | SGR       | S           | NF       |              |
| 13-15                     | Light Yellowish Brown 10YR 6/4 Loamy Sand                         | 0                           | SGR       | S           | NF       |              |
| 15-35                     | Yellowish Brown 10YR 5/4 Loamy Sand                               | < 15                        | SGR       | S           | NF       |              |
| 35-77                     | Brownish Yellow 10YR 6/8 Corse Sand & gravel                      | 15 to < 35                  | SGR       | L           | SF       |              |
| 77-85                     | Brownish Yellow 10YR 6/6 Sand<br>with many dist. 10YR 5/2 mottles | 0                           | SGR       | L           | SF       |              |

SHWT = 52"

OWT = 52"

# SOILS DATA SHEET

Project Number: 225616  
Project Name: South Jersey Gas 24" Gas Line  
Sample Pit #2

Logged by: Steven Ewing  
Date: /21/2014

| <u>Horizon Depth</u><br>(inches) | <u>Horizon Description</u> | <u>Vol. % of</u><br><u>Coarse Fragmts</u> | <u>Structure</u> | <u>Consistence</u> | <u>Moisture</u> | <u>Soil Test ID</u> |
|----------------------------------|----------------------------|---|------------------|--------------------|-----------------|---------------------|
|----------------------------------|----------------------------|---|------------------|--------------------|-----------------|---------------------|

|          |  |     |     |   |    |
|----------|--|-----|-----|---|----|
| 0 – 7    | Yellowish Brown 10YR 5/8 Sandy Clay Loam | 0   | SGR | S | NF |
| 7 – 22   | Dark Yellowish Brown 10YR 4/6 Loamy Sand | 0   | SGR | S | NF |
| 22 – 27  | Yellowish Brown 10YR 5/4 Sandy Clay Loam | 0   | SGR | S | NF |
| 27 – 39  | Yellowish Brown 10YR 5/6 Sandy Clay Loam | 0   | SGR | S | NF |
| 39 – 63  | Brownish Yellow 10YR 6/8 Sand            | <15 | SGR | L | SF |
| 63 – 84  | Pale Brown 10YR 6/3 Sand                 | 0   | SGR | L | SF |
| 84 – 104 | Brownish Yellow 10YR 6/6 Sand            | 0   | SGR | L | SF |

SHWT = 58"    OWT = 58"



Project Number: 225616  
Project Name: South Jersey Gas 24" Gas Line  
Sample Pit #3

Logged by: Steven Ewing  
Date: /21/2014

| <u>Horizon Depth</u><br>(inches) | <u>Horizon Description</u>               | <u>Vol. % of</u><br><u>Coarse Fragmts</u> | <u>Structure</u> | <u>Consistence</u> | <u>Moisture</u> | <u>Soil Test ID</u> |
|----------------------------------|--|---|------------------|--------------------|-----------------|---------------------|
| 0 – 6                            | Brown 10YR 4/3 Sandy Loam                | 0   | SGR              | S                  |                 | NF                  |
| 6 – 18                           | Yellowish Brown 10YR 5/6 Sandy Loam      | < 15                                      | SGR              | S                  |                 | NF                  |
| 18 – 36                          | Brownish Yellow 10YR 6/6 Loamy Sand      | 0   | SGR              | S                  |                 | NF                  |
| 36 – 58                          | Yellowish Brown 10YR 5/6 Sandy Clay Loam | 0   | SGR              | L                  |                 | SF                  |
| 58 – 102                         | Very Pale Brown 10YR 7/3 Sandy Clay Loam | 0   | SGR              | L                  |                 | SF                  |

SHWT = 57"    OWT = 57"



5439 Harding Highway • P.O. Box 427 • Mays Landing, NJ 08330 • P:609.625.1700 • F:609.625.1798

**CLIENT:** Woodard & Curran  
Building 300, Suite 100  
50 Millstone Road  
East Windsor, New Jersey 08520

**ATTN:** Mr. Steven R. Ewing

**PROJECT:** Proposed Recharge Basin  
Mt. Pleasant Tuckahoe Road  
Tuckahoe, New Jersey

CTL No.: 411040

Date: April 1, 2014  
Sample(s) Received: March 21, 2014  
Sample(s) Tested: March 26 to 30, 2014  
Technician: C. Howell, J. Veach

---

### **LABORATORY TEST RESULTS**

| Sample No. | Permeability*<br>k <sub>20</sub> (in/hr) | Soil Permeability<br>Class | Dry<br>Density+ |
|------------|--|----------------------------|-----------------|
| TP-1A      | 5.79                                     | K3                         | 117.3           |
| TP-1B      | 3.00                                     | K3                         | 113.8           |
| TP-2A      | 1.94                                     | K2                         | 123.6           |
| TP-2B      | 1.43                                     | K2                         | 116.7           |
| TP-3A      | 3.74                                     | K3                         | 114.6           |
| TP-3B      | 8.98                                     | K4                         | 119.0           |

\* Permeability corrected to 20<sup>0</sup>C

+ Dry density of tested sample as received in sampling tube

Summary of Laboratory Testing:

Tube Permeameter Test (NJAC 7:9A-6.2) - Undisturbed Total No.  
6

# TUBE PERMEAMETER TEST

(N.J.A.C. 7:9A - Standards for Individual Subsurface Sewage Disposal Systems; Subchapter 6, Section 6.2, page 39, Modified)

Client: Woodard Curran CTL #: 411040  
 Project: Proposed Recharge Basin-Tuchahoe, NJ Date: March 28, 2014  
 Boring/Sample # or Descrip./Location: TP-1A Depth: -  
 Description of Soil: Light Brown silty SAND

Technician: C. Howell, J. Veach Proctor Data: 

|                       |                      |                   |
|-----------------------|----------------------|-------------------|
| Max Dry Density (pcf) | % of Max Dry Density | Opt. Moisture (%) |
| -                     | -                    | -                 |

Initial Specimen Data:

|   |                   |                |               |                   |                   |
|---|-------------------|----------------|---------------|-------------------|-------------------|
| Sample Type:                                    | Water Content (%) | Length, L (in) | Diameter (in) | Wet Density (pcf) | Dry Density (pcf) |
| Undisturbed <input checked="" type="checkbox"/> | 9.3               | 5.11           | 2.875         | 128.2             | 117.3             |
| Re-Compacted <input type="checkbox"/>           |                   |                |               |                   |                   |

Radius of Burette, r: 0.3141 in

Radius of Soil Specimen, R: 1.4375 in

## TEST DATA

| 1  | 2                   |                     | 3    | 4     | 5            |         | 6    | 7     | 8    | 9 |              |                                     |              |                                       |     |
|----|---------------------|---------------------|------|-------|--------------|---------|------|-------|------|---|--------------|-------------------------------------|--------------|---------------------------------------|-----|
|    | Burette Readings    |                     |      |       | Head, h (cm) | Time, t |      |       |      |   | Temp, T (°C) | Permeability at T°C, k <sub>T</sub> | Temp Correc. | Permeability at 20°C, k <sub>20</sub> |     |
|    | h <sub>1</sub> (cm) | h <sub>2</sub> (cm) |      |       |              | Sec     |      |       |      |   |              |                                     |              |                                       | Min |
| 1  | 90.0                | 80.0                | 10.0 | 16.88 | 0.281        | 19.4    | 6.12 | 1.015 | 6.22 |   |              |                                     |              |                                       |     |
| 2  | 90.0                | 80.0                | 10.0 | 17.75 | 0.296        | 19.4    | 5.82 | 1.015 | 5.91 |   |              |                                     |              |                                       |     |
| 3  | 90.0                | 80.0                | 10.0 | 18.13 | 0.302        | 19.4    | 5.70 | 1.015 | 5.79 |   |              |                                     |              |                                       |     |
| 4  | 80.0                | 70.0                | 10.0 | 20.06 | 0.334        | 19.4    | 5.84 | 1.015 | 5.93 |   |              |                                     |              |                                       |     |
| 5  | 80.0                | 70.0                | 10.0 | 20.35 | 0.339        | 19.4    | 5.76 | 1.015 | 5.85 |   |              |                                     |              |                                       |     |
| 6  | 80.0                | 70.0                | 10.0 | 21.31 | 0.355        | 19.4    | 5.50 | 1.015 | 5.58 |   |              |                                     |              |                                       |     |
| 7  | 70.0                | 60.0                | 10.0 | 23.19 | 0.387        | 19.4    | 5.83 | 1.015 | 5.92 |   |              |                                     |              |                                       |     |
| 8  | 70.0                | 60.0                | 10.0 | 24.34 | 0.406        | 19.4    | 5.56 | 1.015 | 5.64 |   |              |                                     |              |                                       |     |
| 9  | 70.0                | 60.0                | 10.0 | 24.81 | 0.414        | 19.4    | 5.45 | 1.015 | 5.54 |   |              |                                     |              |                                       |     |
| 10 | 60.0                | 50.0                | 10.0 | 27.34 | 0.456        | 19.4    | 5.85 | 1.015 | 5.94 |   |              |                                     |              |                                       |     |
| 11 | 60.0                | 50.0                | 10.0 | 28.16 | 0.469        | 19.4    | 5.68 | 1.015 | 5.77 |   |              |                                     |              |                                       |     |
| 12 | 60.0                | 50.0                | 10.0 | 29.09 | 0.485        | 19.4    | 5.50 | 1.015 | 5.58 |   |              |                                     |              |                                       |     |
| 13 | 50.0                | 40.0                | 10.0 | 33.56 | 0.559        | 19.4    | 5.84 | 1.015 | 5.92 |   |              |                                     |              |                                       |     |
| 14 | 50.0                | 40.0                | 10.0 | 34.78 | 0.580        | 19.4    | 5.63 | 1.015 | 5.72 |   |              |                                     |              |                                       |     |
| 15 | 50.0                | 40.0                | 10.0 | 35.94 | 0.599        | 19.4    | 5.45 | 1.015 | 5.53 |   |              |                                     |              |                                       |     |

Perm, k<sub>T</sub> (7) = 60 \* L/t \* r<sup>2</sup>/R<sup>2</sup> \* ln(h<sub>1</sub>/h<sub>2</sub>) = 60 \* L/(5) \* r<sup>2</sup>/R<sup>2</sup> \* ln((2)/(3))

Head, h (4) = (2) - (3); Perm, k<sub>20</sub> (9) = (7)\*(8)

|  |             |
|--|-------------|
| <b>AVERAGE k<sub>20</sub> (in/hr):</b> | <b>5.79</b> |
| <b>SOIL PERMEABILITY CLASS:</b>        | <b>K3</b>   |

**Soil Permeability Classes**

- > 20 inches per hour (in/hr)      K5
- 6 - 20 in/hr                              K4
- 2 - 6 in/hr                                 K3
- 0.6 - 2 in/hr                              K2
- 0.2 - 0.6 in/hr                          K1
- < 0.2 in/hr                                K0

**Remarks**

Plate No.:

# TUBE PERMEAMETER TEST

(N.J.A.C. 7:9A - Standards for Individual Subsurface Sewage Disposal Systems; Subchapter 6, Section 6.2, page 39, Modified)

Client: Woodard Curran CTL #: 411040  
 Project: Proposed Recharge Basin-Tuchahoe, NJ Date: March 28, 2014  
 Boring/Sample # or Descrip./Location: TP-1B Depth: -  
 Description of Soil: Light Brown silty SAND

Technician: C. Howell, J. Veach Proctor Data: 

| Max Dry Density (pcf) | % of Max Dry Density | Opt. Moisture (%) |
|-----------------------|----------------------|-------------------|
| -                     | -                    | -                 |

Initial Specimen Data:

|   |                   |                |               |                   |                   |
|---|-------------------|----------------|---------------|-------------------|-------------------|
| Sample Type:                                    | Water Content (%) | Length, L (in) | Diameter (in) | Wet Density (pcf) | Dry Density (pcf) |
| Undisturbed <input checked="" type="checkbox"/> | 11.8              | 5.31           | 2.875         | 127.2             | 113.8             |
| Re-Compacted <input type="checkbox"/>           |                   |                |               |                   |                   |

Radius of Burette, r: 0.3141 in

Radius of Soil Specimen, R: 1.4375 in

## TEST DATA

| 1  | 2                   |                     | 3    | 4     | 5            |         | 6    | 7     | 8    | 9 |              |                                     |              |                                       |     |
|----|---------------------|---------------------|------|-------|--------------|---------|------|-------|------|---|--------------|-------------------------------------|--------------|---------------------------------------|-----|
|    | Burette Readings    |                     |      |       | Head, h (cm) | Time, t |      |       |      |   | Temp, T (°C) | Permeability at T°C, k <sub>T</sub> | Temp Correc. | Permeability at 20°C, k <sub>20</sub> |     |
|    | h <sub>1</sub> (cm) | h <sub>2</sub> (cm) |      |       |              | Sec     |      |       |      |   |              |                                     |              |                                       | Min |
| 1  | 90.0                | 80.0                | 10.0 | 34.31 | 0.572        | 19.4    | 3.13 | 1.015 | 3.18 |   |              |                                     |              |                                       |     |
| 2  | 90.0                | 80.0                | 10.0 | 37.97 | 0.633        | 19.4    | 2.83 | 1.015 | 2.87 |   |              |                                     |              |                                       |     |
| 3  | 90.0                | 80.0                | 10.0 | 34.10 | 0.568        | 19.4    | 3.15 | 1.015 | 3.20 |   |              |                                     |              |                                       |     |
| 4  | 80.0                | 70.0                | 10.0 | 38.53 | 0.642        | 19.4    | 3.16 | 1.015 | 3.21 |   |              |                                     |              |                                       |     |
| 5  | 80.0                | 70.0                | 10.0 | 41.53 | 0.692        | 19.4    | 2.93 | 1.015 | 2.98 |   |              |                                     |              |                                       |     |
| 6  | 80.0                | 70.0                | 10.0 | 38.97 | 0.650        | 19.4    | 3.13 | 1.015 | 3.17 |   |              |                                     |              |                                       |     |
| 7  | 70.0                | 60.0                | 10.0 | 46.28 | 0.771        | 19.4    | 3.04 | 1.015 | 3.09 |   |              |                                     |              |                                       |     |
| 8  | 70.0                | 60.0                | 10.0 | 48.94 | 0.816        | 19.4    | 2.87 | 1.015 | 2.92 |   |              |                                     |              |                                       |     |
| 9  | 70.0                | 60.0                | 10.0 | 46.40 | 0.773        | 19.4    | 3.03 | 1.015 | 3.08 |   |              |                                     |              |                                       |     |
| 10 | 60.0                | 50.0                | 10.0 | 56.65 | 0.944        | 19.4    | 2.94 | 1.015 | 2.98 |   |              |                                     |              |                                       |     |
| 11 | 60.0                | 50.0                | 10.0 | 60.63 | 1.011        | 19.4    | 2.74 | 1.015 | 2.79 |   |              |                                     |              |                                       |     |
| 12 | 60.0                | 50.0                | 10.0 | 58.16 | 0.969        | 19.4    | 2.86 | 1.015 | 2.90 |   |              |                                     |              |                                       |     |
| 13 | 50.0                | 40.0                | 10.0 | 71.63 | 1.194        | 19.4    | 2.84 | 1.015 | 2.89 |   |              |                                     |              |                                       |     |
| 14 | 50.0                | 40.0                | 10.0 | 75.03 | 1.251        | 19.4    | 2.71 | 1.015 | 2.76 |   |              |                                     |              |                                       |     |
| 15 | 50.0                | 40.0                | 10.0 | 70.56 | 1.176        | 19.4    | 2.89 | 1.015 | 2.93 |   |              |                                     |              |                                       |     |

Perm, k<sub>T</sub> (7) = 60 \* L/t \* r<sup>2</sup>/R<sup>2</sup> \* ln(h<sub>1</sub>/h<sub>2</sub>) = 60 \* L/(5) \* r<sup>2</sup>/R<sup>2</sup> \* ln((2)/(3))

Head, h (4) = (2) - (3); Perm, k<sub>20</sub> (9) = (7)\*(8)

|  |             |
|--|-------------|
| <b>AVERAGE k<sub>20</sub> (in/hr):</b> | <b>3.00</b> |
| <b>SOIL PERMEABILITY CLASS:</b>        | <b>K3</b>   |

**Soil Permeability Classes**

- > 20 inches per hour (in/hr)      K5
- 6 - 20 in/hr                              K4
- 2 - 6 in/hr                                 K3
- 0.6 - 2 in/hr                              K2
- 0.2 - 0.6 in/hr                          K1
- < 0.2 in/hr                                K0

**Remarks**

Plate No.:

# TUBE PERMEAMETER TEST

(N.J.A.C. 7:9A - Standards for Individual Subsurface Sewage Disposal Systems; Subchapter 6, Section 6.2, page 39, Modified)

Client: Woodard Curran CTL #: 411040  
 Project: Proposed Recharge Basin-Tuchahoe, NJ Date: March 28, 2014  
 Boring/Sample # or Descrip./Location: TP-2A Depth: -  
 Description of Soil: Brown Clayey SAND tr. Gravel

Technician: C. Howell, J. Veach Proctor Data: 

| Max Dry Density (pcf) | % of Max Dry Density | Opt. Moisture (%) |
|-----------------------|----------------------|-------------------|
| -                     | -                    | -                 |

Initial Specimen Data:

|   |                   |                |               |                   |                   |
|---|-------------------|----------------|---------------|-------------------|-------------------|
| Sample Type:                                    | Water Content (%) | Length, L (in) | Diameter (in) | Wet Density (pcf) | Dry Density (pcf) |
| Undisturbed <input checked="" type="checkbox"/> | 9.6               | 4.62           | 2.875         | 135.5             | 123.6             |
| Re-Compacted <input type="checkbox"/>           |                   |                |               |                   |                   |

Radius of Burette, r: 0.3141 in

Radius of Soil Specimen, R: 1.4375 in

## TEST DATA

| 1  | 2                   |                     | 3    | 4     | 5            |         | 6    | 7     | 8    | 9 |              |                                     |              |                                       |     |
|----|---------------------|---------------------|------|-------|--------------|---------|------|-------|------|---|--------------|-------------------------------------|--------------|---------------------------------------|-----|
|    | Burette Readings    |                     |      |       | Head, h (cm) | Time, t |      |       |      |   | Temp, T (°C) | Permeability at T°C, k <sub>T</sub> | Temp Correc. | Permeability at 20°C, k <sub>20</sub> |     |
|    | h <sub>1</sub> (cm) | h <sub>2</sub> (cm) |      |       |              | Sec     |      |       |      |   |              |                                     |              |                                       | Min |
| 1  | 90.0                | 80.0                | 10.0 | 48.00 | 0.800        | 19.3    | 1.95 | 1.018 | 1.98 |   |              |                                     |              |                                       |     |
| 2  | 90.0                | 80.0                | 10.0 | 48.25 | 0.804        | 19.3    | 1.94 | 1.018 | 1.97 |   |              |                                     |              |                                       |     |
| 3  | 90.0                | 80.0                | 10.0 | 47.25 | 0.788        | 19.3    | 1.98 | 1.018 | 2.01 |   |              |                                     |              |                                       |     |
| 4  | 80.0                | 70.0                | 10.0 | 58.44 | 0.974        | 19.3    | 1.81 | 1.018 | 1.85 |   |              |                                     |              |                                       |     |
| 5  | 80.0                | 70.0                | 10.0 | 56.10 | 0.935        | 19.3    | 1.89 | 1.018 | 1.92 |   |              |                                     |              |                                       |     |
| 6  | 80.0                | 70.0                | 10.0 | 56.12 | 0.935        | 19.3    | 1.89 | 1.018 | 1.92 |   |              |                                     |              |                                       |     |
| 7  | 70.0                | 60.0                | 10.0 | 64.66 | 1.078        | 19.3    | 1.89 | 1.018 | 1.93 |   |              |                                     |              |                                       |     |
| 8  | 70.0                | 60.0                | 10.0 | 67.57 | 1.126        | 19.3    | 1.81 | 1.018 | 1.84 |   |              |                                     |              |                                       |     |
| 9  | 70.0                | 60.0                | 10.0 | 68.03 | 1.134        | 19.3    | 1.80 | 1.018 | 1.83 |   |              |                                     |              |                                       |     |
| 10 | 60.0                | 50.0                | 10.0 | 76.90 | 1.282        | 19.3    | 1.88 | 1.018 | 1.91 |   |              |                                     |              |                                       |     |
| 11 | 60.0                | 50.0                | 10.0 | 74.97 | 1.250        | 19.3    | 1.93 | 1.018 | 1.96 |   |              |                                     |              |                                       |     |
| 12 | 60.0                | 50.0                | 10.0 | 76.81 | 1.280        | 19.3    | 1.88 | 1.018 | 1.92 |   |              |                                     |              |                                       |     |
| 13 | 50.0                | 40.0                | 10.0 | 89.10 | 1.485        | 19.3    | 1.99 | 1.018 | 2.02 |   |              |                                     |              |                                       |     |
| 14 | 50.0                | 40.0                | 10.0 | 89.82 | 1.497        | 19.3    | 1.97 | 1.018 | 2.01 |   |              |                                     |              |                                       |     |
| 15 | 50.0                | 40.0                | 10.0 | 90.50 | 1.508        | 19.3    | 1.96 | 1.018 | 1.99 |   |              |                                     |              |                                       |     |

Perm, k<sub>T</sub> (7) = 60 \* L/t \* r<sup>2</sup>/R<sup>2</sup> \* ln(h<sub>1</sub>/h<sub>2</sub>) = 60 \* L/(5) \* r<sup>2</sup>/R<sup>2</sup> \* ln((2)/(3))

Head, h (4) = (2) - (3); Perm, k<sub>20</sub> (9) = (7)\*(8)

|  |             |
|--|-------------|
| <b>AVERAGE k<sub>20</sub> (in/hr):</b> | <b>1.94</b> |
| <b>SOIL PERMEABILITY CLASS:</b>        | <b>K2</b>   |

**Soil Permeability Classes**

- > 20 inches per hour (in/hr)      K5
- 6 - 20 in/hr                              K4
- 2 - 6 in/hr                                K3
- 0.6 - 2 in/hr                            K2
- 0.2 - 0.6 in/hr                        K1
- < 0.2 in/hr                              K0

**Remarks**

- Tube was not full with sample.

Plate No.:

# TUBE PERMEAMETER TEST

(N.J.A.C. 7:9A - Standards for Individual Subsurface Sewage Disposal Systems; Subchapter 6, Section 6.2, page 39, Modified)

Client: Woodard Curran CTL #: 411040  
 Project: Proposed Recharge Basin-Tuchahoe, NJ Date: March 28, 2014  
 Boring/Sample # or Descrip./Location: TP-2B Depth: -  
 Description of Soil: Brown Clayey SAND

Technician: C. Howell, J. Veach Proctor Data: 

| Max Dry Density (pcf) | % of Max Dry Density | Opt. Moisture (%) |
|-----------------------|----------------------|-------------------|
| -                     | -                    | -                 |

Initial Specimen Data:

|   |                   |                |               |                   |                   |
|---|-------------------|----------------|---------------|-------------------|-------------------|
| Sample Type:                                    | Water Content (%) | Length, L (in) | Diameter (in) | Wet Density (pcf) | Dry Density (pcf) |
| Undisturbed <input checked="" type="checkbox"/> | 10.4              | 4.83           | 2.875         | 128.9             | 116.7             |
| Re-Compacted <input type="checkbox"/>           |                   |                |               |                   |                   |

Radius of Burette, r: 0.3141 in

Radius of Soil Specimen, R: 1.4375 in

## TEST DATA

| 1  | 2                   |                     | 3    | 4      | 5            |         | 6    | 7     | 8    | 9 |              |                                     |              |                                       |     |
|----|---------------------|---------------------|------|--------|--------------|---------|------|-------|------|---|--------------|-------------------------------------|--------------|---------------------------------------|-----|
|    | Burette Readings    |                     |      |        | Head, h (cm) | Time, t |      |       |      |   | Temp, T (°C) | Permeability at T°C, k <sub>T</sub> | Temp Correc. | Permeability at 20°C, k <sub>20</sub> |     |
|    | h <sub>1</sub> (cm) | h <sub>2</sub> (cm) |      |        |              | Sec     |      |       |      |   |              |                                     |              |                                       | Min |
| 1  | 90.0                | 80.0                | 10.0 | 63.47  | 1.058        | 19.6    | 1.54 | 1.010 | 1.56 |   |              |                                     |              |                                       |     |
| 2  | 90.0                | 80.0                | 10.0 | 67.78  | 1.130        | 19.6    | 1.44 | 1.010 | 1.46 |   |              |                                     |              |                                       |     |
| 3  | 90.0                | 80.0                | 10.0 | 59.07  | 0.985        | 19.6    | 1.65 | 1.010 | 1.67 |   |              |                                     |              |                                       |     |
| 4  | 80.0                | 70.0                | 10.0 | 74.69  | 1.245        | 19.6    | 1.48 | 1.010 | 1.50 |   |              |                                     |              |                                       |     |
| 5  | 80.0                | 70.0                | 10.0 | 77.80  | 1.297        | 19.6    | 1.42 | 1.010 | 1.44 |   |              |                                     |              |                                       |     |
| 6  | 80.0                | 70.0                | 10.0 | 81.81  | 1.364        | 19.6    | 1.35 | 1.010 | 1.37 |   |              |                                     |              |                                       |     |
| 7  | 70.0                | 60.0                | 10.0 | 91.79  | 1.530        | 19.6    | 1.39 | 1.010 | 1.41 |   |              |                                     |              |                                       |     |
| 8  | 70.0                | 60.0                | 10.0 | 98.81  | 1.647        | 19.6    | 1.29 | 1.010 | 1.31 |   |              |                                     |              |                                       |     |
| 9  | 70.0                | 60.0                | 10.0 | 102.90 | 1.715        | 19.6    | 1.24 | 1.010 | 1.26 |   |              |                                     |              |                                       |     |
| 10 | 60.0                | 50.0                | 10.0 | 110.38 | 1.840        | 19.6    | 1.37 | 1.010 | 1.38 |   |              |                                     |              |                                       |     |
| 11 | 60.0                | 50.0                | 10.0 | 116.07 | 1.935        | 19.6    | 1.30 | 1.010 | 1.32 |   |              |                                     |              |                                       |     |
| 12 | 60.0                | 50.0                | 10.0 | 113.08 | 1.885        | 19.6    | 1.34 | 1.010 | 1.35 |   |              |                                     |              |                                       |     |
| 13 | 50.0                | 40.0                | 10.0 | 125.16 | 2.086        | 19.6    | 1.48 | 1.010 | 1.49 |   |              |                                     |              |                                       |     |
| 14 | 50.0                | 40.0                | 10.0 | 123.16 | 2.053        | 19.6    | 1.50 | 1.010 | 1.52 |   |              |                                     |              |                                       |     |
| 15 | 50.0                | 40.0                | 10.0 | 136.69 | 2.278        | 19.6    | 1.35 | 1.010 | 1.37 |   |              |                                     |              |                                       |     |

Perm, k<sub>T</sub> (7) = 60 \* L/t \* r<sup>2</sup>/R<sup>2</sup> \* ln(h<sub>1</sub>/h<sub>2</sub>) = 60 \* L/(5) \* r<sup>2</sup>/R<sup>2</sup> \* ln((2)/(3))

Head, h (4) = (2) - (3); Perm, k<sub>20</sub> (9) = (7)\*(8)

|  |             |
|--|-------------|
| <b>AVERAGE k<sub>20</sub> (in/hr):</b> | <b>1.43</b> |
| <b>SOIL PERMEABILITY CLASS:</b>        | <b>K2</b>   |

**Soil Permeability Classes**

- > 20 inches per hour (in/hr)      K5
- 6 - 20 in/hr                              K4
- 2 - 6 in/hr                                 K3
- 0.6 - 2 in/hr                              K2
- 0.2 - 0.6 in/hr                          K1
- < 0.2 in/hr                                K0

**Remarks**

Plate No.:

# TUBE PERMEAMETER TEST

(N.J.A.C. 7:9A - Standards for Individual Subsurface Sewage Disposal Systems; Subchapter 6, Section 6.2, page 39, Modified)

Client: Woodard Curran CTL #: 411040  
 Project: Proposed Recharge Basin-Tuchahoe, NJ Date: March 28, 2014  
 Boring/Sample # or Descrip./Location: TP-3A Depth: -  
 Description of Soil: Brown Clayey SAND

Technician: C. Howell, J. Veach Proctor Data: 

| Max Dry Density (pcf) | % of Max Dry Density | Opt. Moisture (%) |
|-----------------------|----------------------|-------------------|
| -                     | -                    | -                 |

Initial Specimen Data:

|   |                   |                |               |                   |                   |
|---|-------------------|----------------|---------------|-------------------|-------------------|
| Sample Type:                                    | Water Content (%) | Length, L (in) | Diameter (in) | Wet Density (pcf) | Dry Density (pcf) |
| Undisturbed <input checked="" type="checkbox"/> | 10.4              | 5.17           | 2.875         | 126.6             | 114.6             |
| Re-Compacted <input type="checkbox"/>           |                   |                |               |                   |                   |

Radius of Burette, r: 0.3141 in

Radius of Soil Specimen, R: 1.4375 in

## TEST DATA

| 1  | 2                   |                     | 3            | 4       | 5            |                                     | 6            | 7                                     | 8    | 9 |
|----|---------------------|---------------------|--------------|---------|--------------|-------------------------------------|--------------|---------------------------------------|------|---|
|    | Burette Readings    |                     | Head, h (cm) | Time, t | Temp, T (°C) | Permeability at T°C, k <sub>T</sub> | Temp Correc. | Permeability at 20°C, k <sub>20</sub> |      |   |
|    | h <sub>1</sub> (cm) | h <sub>2</sub> (cm) |              |         |              |                                     |              |                                       |      |   |
| 1  | 90.0                | 80.0                | 10.0         | 28.19   | 0.470        | 19.7                                | 3.71         | 1.008                                 | 3.74 |   |
| 2  | 90.0                | 80.0                | 10.0         | 27.00   | 0.450        | 19.7                                | 3.87         | 1.008                                 | 3.90 |   |
| 3  | 90.0                | 80.0                | 10.0         | 27.31   | 0.455        | 19.7                                | 3.83         | 1.008                                 | 3.86 |   |
| 4  | 80.0                | 70.0                | 10.0         | 33.90   | 0.565        | 19.7                                | 3.50         | 1.008                                 | 3.52 |   |
| 5  | 80.0                | 70.0                | 10.0         | 31.88   | 0.531        | 19.7                                | 3.72         | 1.008                                 | 3.75 |   |
| 6  | 80.0                | 70.0                | 10.0         | 33.28   | 0.555        | 19.7                                | 3.56         | 1.008                                 | 3.59 |   |
| 7  | 70.0                | 60.0                | 10.0         | 35.84   | 0.597        | 19.7                                | 3.82         | 1.008                                 | 3.85 |   |
| 8  | 70.0                | 60.0                | 10.0         | 37.00   | 0.617        | 19.7                                | 3.70         | 1.008                                 | 3.73 |   |
| 9  | 70.0                | 60.0                | 10.0         | 37.84   | 0.631        | 19.7                                | 3.62         | 1.008                                 | 3.64 |   |
| 10 | 60.0                | 50.0                | 10.0         | 44.87   | 0.748        | 19.7                                | 3.61         | 1.008                                 | 3.64 |   |
| 11 | 60.0                | 50.0                | 10.0         | 43.97   | 0.733        | 19.7                                | 3.68         | 1.008                                 | 3.71 |   |
| 12 | 60.0                | 50.0                | 10.0         | 44.25   | 0.738        | 19.7                                | 3.66         | 1.008                                 | 3.69 |   |
| 13 | 50.0                | 40.0                | 10.0         | 55.28   | 0.921        | 19.7                                | 3.58         | 1.008                                 | 3.61 |   |
| 14 | 50.0                | 40.0                | 10.0         | 53.43   | 0.891        | 19.7                                | 3.71         | 1.008                                 | 3.74 |   |
| 15 | 50.0                | 40.0                | 10.0         | 52.53   | 0.876        | 19.7                                | 3.77         | 1.008                                 | 3.80 |   |

Perm, k<sub>T</sub> (7) = 60 \* L/t \* r<sup>2</sup>/R<sup>2</sup> \* ln(h1/h2) = 60 \* L/(5) \* r<sup>2</sup>/R<sup>2</sup> \* ln((2)/(3))

Head, h (4) = (2) - (3); Perm, k<sub>20</sub> (9) = (7)\*(8)

|  |             |
|--|-------------|
| <b>AVERAGE k<sub>20</sub> (in/hr):</b> | <b>3.72</b> |
| <b>SOIL PERMEABILITY CLASS:</b>        | <b>K3</b>   |

**Soil Permeability Classes**

- > 20 inches per hour (in/hr)      K5
- 6 - 20 in/hr                              K4
- 2 - 6 in/hr                                 K3
- 0.6 - 2 in/hr                              K2
- 0.2 - 0.6 in/hr                          K1
- < 0.2 in/hr                                K0

**Remarks**

Plate No.:

# TUBE PERMEAMETER TEST

(N.J.A.C. 7:9A - Standards for Individual Subsurface Sewage Disposal Systems; Subchapter 6, Section 6.2, page 39, Modified)

Client: Woodard Curran CTL #: 411040  
 Project: Proposed Recharge Basin-Tuchahoe, NJ Date: March 28, 2014  
 Boring/Sample # or Descrip./Location: TP-3B Depth: -  
 Description of Soil: Brown Clayey SAND tr. Gravel

Technician: C. Howell, J. Veach Proctor Data: 

| Max Dry Density (pcf) | % of Max Dry Density | Opt. Moisture (%) |
|-----------------------|----------------------|-------------------|
| -                     | -                    | -                 |

Initial Specimen Data:

|   |                   |                |               |                   |                   |
|---|-------------------|----------------|---------------|-------------------|-------------------|
| Sample Type:                                    | Water Content (%) | Length, L (in) | Diameter (in) | Wet Density (pcf) | Dry Density (pcf) |
| Undisturbed <input checked="" type="checkbox"/> | 11.7              | 4.53           | 2.875         | 132.9             | 119.0             |
| Re-Compacted <input type="checkbox"/>           |                   |                |               |                   |                   |

Radius of Burette, r: 0.3141 in

Radius of Soil Specimen, R: 1.4375 in

## TEST DATA

| 1  | 2                   |                     | 3    | 4     | 5            |         | 6    | 7     | 8    | 9 |              |                                     |              |                                       |     |
|----|---------------------|---------------------|------|-------|--------------|---------|------|-------|------|---|--------------|-------------------------------------|--------------|---------------------------------------|-----|
|    | Burette Readings    |                     |      |       | Head, h (cm) | Time, t |      |       |      |   | Temp, T (°C) | Permeability at T°C, k <sub>T</sub> | Temp Correc. | Permeability at 20°C, k <sub>20</sub> |     |
|    | h <sub>1</sub> (cm) | h <sub>2</sub> (cm) |      |       |              | Sec     |      |       |      |   |              |                                     |              |                                       | Min |
| 1  | 90.0                | 80.0                | 10.0 | 10.66 | 0.178        | 19.5    | 8.59 | 1.013 | 8.70 |   |              |                                     |              |                                       |     |
| 2  | 90.0                | 80.0                | 10.0 | 10.60 | 0.177        | 19.5    | 8.64 | 1.013 | 8.75 |   |              |                                     |              |                                       |     |
| 3  | 90.0                | 80.0                | 10.0 | 10.22 | 0.170        | 19.5    | 8.96 | 1.013 | 9.08 |   |              |                                     |              |                                       |     |
| 4  | 80.0                | 70.0                | 10.0 | 11.24 | 0.187        | 19.5    | 9.24 | 1.013 | 9.36 |   |              |                                     |              |                                       |     |
| 5  | 80.0                | 70.0                | 10.0 | 11.92 | 0.199        | 19.5    | 8.71 | 1.013 | 8.82 |   |              |                                     |              |                                       |     |
| 6  | 80.0                | 70.0                | 10.0 | 11.16 | 0.186        | 19.5    | 9.31 | 1.013 | 9.42 |   |              |                                     |              |                                       |     |
| 7  | 70.0                | 60.0                | 10.0 | 14.00 | 0.233        | 19.5    | 8.56 | 1.013 | 8.67 |   |              |                                     |              |                                       |     |
| 8  | 70.0                | 60.0                | 10.0 | 14.31 | 0.239        | 19.5    | 8.38 | 1.013 | 8.48 |   |              |                                     |              |                                       |     |
| 9  | 70.0                | 60.0                | 10.0 | 13.78 | 0.230        | 19.5    | 8.70 | 1.013 | 8.81 |   |              |                                     |              |                                       |     |
| 10 | 60.0                | 50.0                | 10.0 | 15.72 | 0.262        | 19.5    | 9.02 | 1.013 | 9.13 |   |              |                                     |              |                                       |     |
| 11 | 60.0                | 50.0                | 10.0 | 16.97 | 0.283        | 19.5    | 8.36 | 1.013 | 8.46 |   |              |                                     |              |                                       |     |
| 12 | 60.0                | 50.0                | 10.0 | 15.86 | 0.264        | 19.5    | 8.94 | 1.013 | 9.05 |   |              |                                     |              |                                       |     |
| 13 | 50.0                | 40.0                | 10.0 | 19.00 | 0.317        | 19.5    | 9.13 | 1.013 | 9.25 |   |              |                                     |              |                                       |     |
| 14 | 50.0                | 40.0                | 10.0 | 19.65 | 0.328        | 19.5    | 8.83 | 1.013 | 8.94 |   |              |                                     |              |                                       |     |
| 15 | 50.0                | 40.0                | 10.0 | 18.00 | 0.300        | 19.5    | 9.64 | 1.013 | 9.76 |   |              |                                     |              |                                       |     |

Perm, k<sub>T</sub> (7) = 60 \* L/t \* r<sup>2</sup>/R<sup>2</sup> \* ln(h<sub>1</sub>/h<sub>2</sub>) = 60 \* L/(5) \* r<sup>2</sup>/R<sup>2</sup> \* ln((2)/(3))

Head, h (4) = (2) - (3); Perm, k<sub>20</sub> (9) = (7)\*(8)

|  |             |
|--|-------------|
| <b>AVERAGE k<sub>20</sub> (in/hr):</b> | <b>8.98</b> |
| <b>SOIL PERMEABILITY CLASS:</b>        | <b>K4</b>   |

**Soil Permeability Classes**

- > 20 inches per hour (in/hr)      K5
- 6 - 20 in/hr                              K4
- 2 - 6 in/hr                                 K3
- 0.6 - 2 in/hr                              K2
- 0.2 - 0.6 in/hr                         K1
- < 0.2 in/hr                                K0

**Remarks**

- Tube was not full with sample.

Plate No.:



## APPENDIX D: PRE-DEVELOPMENT ANALYSIS

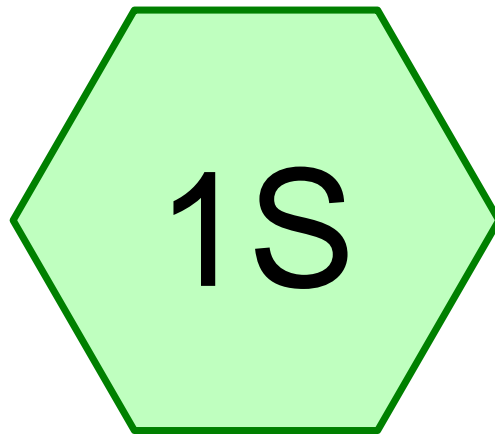

# Existing WSD A - To Mount Pleasant Road

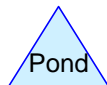
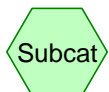

**2014.10.17 HydroCAD**

Prepared by W&C

HydroCAD® 10.00 s/n 01204 © 2012 HydroCAD Software Solutions LLC

---

*Type III 24-hr 2 Year Rainfall=3.35"*

Printed 10/17/2014

Time span=0.00-72.00 hrs, dt=0.01 hrs, 7201 points

Runoff by SCS TR-20 method, UH=SCS

Reach routing by Stor-Ind+Trans method - Pond routing by Stor-Ind method

**Subcatchment 1S: Existing WSD A - To**

Runoff Area=1.550 ac 0.00% Impervious Runoff Depth=0.55"  
Flow Length=387' Tc=14.7 min CN=62 Runoff=0.54 cfs 0.071 af

**Total Runoff Area = 1.550 ac Runoff Volume = 0.071 af Average Runoff Depth = 0.55"**  
**100.00% Pervious = 1.550 ac 0.00% Impervious = 0.000 ac**

**Summary for Subcatchment 1S: Existing WSD A - To Mount Pleasant Road**

Runoff = 0.54 cfs @ 12.26 hrs, Volume= 0.071 af, Depth= 0.55"

Runoff by SCS TR-20 method, UH=SCS, Time Span= 0.00-72.00 hrs, dt= 0.01 hrs  
 Type III 24-hr 2 Year Rainfall=3.35"

| Area (ac) | CN | Description                    |
|-----------|----|--------------------------------|
| 0.440     | 58 | Woods/grass comb., Good, HSG B |
| * 0.170   | 82 | Baseball Field, HSG B          |
| 0.940     | 61 | >75% Grass cover, Good, HSG B  |
| 1.550     | 62 | Weighted Average               |
| 1.550     |    | 100.00% Pervious Area          |

| Tc (min) | Length (feet) | Slope (ft/ft) | Velocity (ft/sec) | Capacity (cfs) | Description                          |
|----------|---------------|---------------|-------------------|----------------|--------------------------------------|
| 10.5     | 50            | 0.0040        | 0.08              |                | <b>Sheet Flow, AB</b>                |
|          |               |               |                   |                | Grass: Short n= 0.150 P2= 3.35"      |
| 4.2      | 337           | 0.0080        | 1.34              |                | <b>Shallow Concentrated Flow, BC</b> |
|          |               |               |                   |                | Grassed Waterway Kv= 15.0 fps        |
| 14.7     | 387           | Total         |                   |                |                                      |

**2014.10.17 HydroCAD**

Prepared by W&C

HydroCAD® 10.00 s/n 01204 © 2012 HydroCAD Software Solutions LLC

---

Type III 24-hr 10 Year Rainfall=5.21"

Printed 10/17/2014

Time span=0.00-72.00 hrs, dt=0.01 hrs, 7201 points

Runoff by SCS TR-20 method, UH=SCS

Reach routing by Stor-Ind+Trans method - Pond routing by Stor-Ind method

**Subcatchment 1S: Existing WSD A - To**

Runoff Area=1.550 ac 0.00% Impervious Runoff Depth=1.57"  
Flow Length=387' Tc=14.7 min CN=62 Runoff=2.01 cfs 0.203 af

**Total Runoff Area = 1.550 ac Runoff Volume = 0.203 af Average Runoff Depth = 1.57"**  
**100.00% Pervious = 1.550 ac 0.00% Impervious = 0.000 ac**

**Summary for Subcatchment 1S: Existing WSD A - To Mount Pleasant Road**

Runoff = 2.01 cfs @ 12.22 hrs, Volume= 0.203 af, Depth= 1.57"

Runoff by SCS TR-20 method, UH=SCS, Time Span= 0.00-72.00 hrs, dt= 0.01 hrs  
 Type III 24-hr 10 Year Rainfall=5.21"

| Area (ac) | CN | Description                    |
|-----------|----|--------------------------------|
| 0.440     | 58 | Woods/grass comb., Good, HSG B |
| * 0.170   | 82 | Baseball Field, HSG B          |
| 0.940     | 61 | >75% Grass cover, Good, HSG B  |
| 1.550     | 62 | Weighted Average               |
| 1.550     |    | 100.00% Pervious Area          |

| Tc (min) | Length (feet) | Slope (ft/ft) | Velocity (ft/sec) | Capacity (cfs) | Description                          |
|----------|---------------|---------------|-------------------|----------------|--------------------------------------|
| 10.5     | 50            | 0.0040        | 0.08              |                | <b>Sheet Flow, AB</b>                |
|          |               |               |                   |                | Grass: Short n= 0.150 P2= 3.35"      |
| 4.2      | 337           | 0.0080        | 1.34              |                | <b>Shallow Concentrated Flow, BC</b> |
|          |               |               |                   |                | Grassed Waterway Kv= 15.0 fps        |
| 14.7     | 387           | Total         |                   |                |                                      |

**2014.10.17 HydroCAD**

Type III 24-hr 100 Year Rainfall=9.00"

Prepared by W&C

Printed 10/17/2014

HydroCAD® 10.00 s/n 01204 © 2012 HydroCAD Software Solutions LLC

---

Time span=0.00-72.00 hrs, dt=0.01 hrs, 7201 points

Runoff by SCS TR-20 method, UH=SCS

Reach routing by Stor-Ind+Trans method - Pond routing by Stor-Ind method

**Subcatchment 1S: Existing WSD A - To**

Runoff Area=1.550 ac 0.00% Impervious Runoff Depth=4.35"  
Flow Length=387' Tc=14.7 min CN=62 Runoff=6.00 cfs 0.561 af

**Total Runoff Area = 1.550 ac Runoff Volume = 0.561 af Average Runoff Depth = 4.35"**  
**100.00% Pervious = 1.550 ac 0.00% Impervious = 0.000 ac**

**Summary for Subcatchment 1S: Existing WSD A - To Mount Pleasant Road**

Runoff = 6.00 cfs @ 12.20 hrs, Volume= 0.561 af, Depth= 4.35"

Runoff by SCS TR-20 method, UH=SCS, Time Span= 0.00-72.00 hrs, dt= 0.01 hrs  
 Type III 24-hr 100 Year Rainfall=9.00"

| Area (ac) | CN | Description                    |
|-----------|----|--------------------------------|
| 0.440     | 58 | Woods/grass comb., Good, HSG B |
| * 0.170   | 82 | Baseball Field, HSG B          |
| 0.940     | 61 | >75% Grass cover, Good, HSG B  |
| 1.550     | 62 | Weighted Average               |
| 1.550     |    | 100.00% Pervious Area          |

| Tc (min) | Length (feet) | Slope (ft/ft) | Velocity (ft/sec) | Capacity (cfs) | Description                          |
|----------|---------------|---------------|-------------------|----------------|--------------------------------------|
| 10.5     | 50            | 0.0040        | 0.08              |                | <b>Sheet Flow, AB</b>                |
|          |               |               |                   |                | Grass: Short n= 0.150 P2= 3.35"      |
| 4.2      | 337           | 0.0080        | 1.34              |                | <b>Shallow Concentrated Flow, BC</b> |
|          |               |               |                   |                | Grassed Waterway Kv= 15.0 fps        |
| 14.7     | 387           | Total         |                   |                |                                      |



## APPENDIX E: POST-DEVELOPMENT ANALYSIS

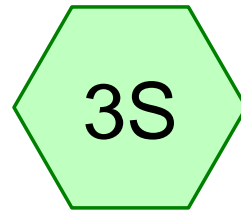
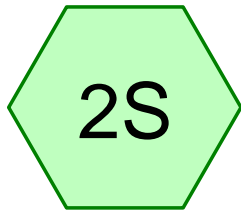

Proposed WSD A-1 - To  
Proposed Infiltration  
Area

Proposed WSD A-2 -  
Direct to Mount  
Pleasant Road

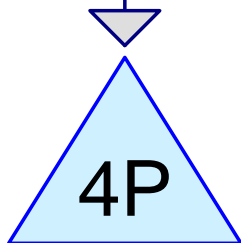

Crushed Stone  
Infiltration Area

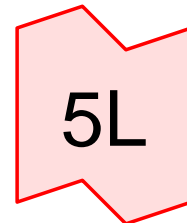

Proposed WSD A - To  
Mount Pleasant Road

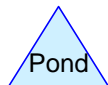
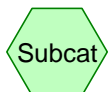

**2014.10.17 HydroCAD**

Prepared by W&C

HydroCAD® 10.00 s/n 01204 © 2012 HydroCAD Software Solutions LLC

*Type III 24-hr 2 Year Rainfall=3.35"*

Printed 10/17/2014

Time span=0.00-72.00 hrs, dt=0.01 hrs, 7201 points

Runoff by SCS TR-20 method, UH=SCS

Reach routing by Stor-Ind+Trans method - Pond routing by Stor-Ind method

**Subcatchment 2S: Proposed WSD A-1 - To** Runoff Area=0.790 ac 63.29% Impervious Runoff Depth=1.89"  
Tc=0.0 min CN=85 Runoff=2.14 cfs 0.124 af

**Subcatchment 3S: Proposed WSD A-2 -** Runoff Area=0.760 ac 0.00% Impervious Runoff Depth=0.59"  
Flow Length=352' Tc=16.6 min CN=63 Runoff=0.28 cfs 0.037 af

**Pond 4P: Crushed Stone Infiltration Area** Peak Elev=18.58' Storage=679 cf Inflow=2.14 cfs 0.124 af  
Discarded=0.71 cfs 0.124 af Primary=0.00 cfs 0.000 af Outflow=0.71 cfs 0.124 af

**Link 5L: Proposed WSD A - To Mount Pleasant Road** Inflow=0.28 cfs 0.037 af  
Primary=0.28 cfs 0.037 af

**Total Runoff Area = 1.550 ac Runoff Volume = 0.161 af Average Runoff Depth = 1.25"**  
**67.74% Pervious = 1.050 ac 32.26% Impervious = 0.500 ac**

**Summary for Subcatchment 2S: Proposed WSD A-1 - To Proposed Infiltration Area**

Runoff = 2.14 cfs @ 12.00 hrs, Volume= 0.124 af, Depth= 1.89"

Runoff by SCS TR-20 method, UH=SCS, Time Span= 0.00-72.00 hrs, dt= 0.01 hrs  
 Type III 24-hr 2 Year Rainfall=3.35"

| Area (ac) | CN | Description                    |
|-----------|----|--------------------------------|
| * 0.500   | 98 | Crushed stone, HSG B           |
| 0.190     | 61 | >75% Grass cover, Good, HSG B  |
| * 0.030   | 82 | Baseball Field, HSG B          |
| 0.070     | 58 | Woods/grass comb., Good, HSG B |
| 0.790     | 85 | Weighted Average               |
| 0.290     |    | 36.71% Pervious Area           |
| 0.500     |    | 63.29% Impervious Area         |

| Tc (min) | Length (feet) | Slope (ft/ft) | Velocity (ft/sec) | Capacity (cfs) | Description                                  |
|----------|---------------|---------------|-------------------|----------------|--|
| 0.0      |               |               |                   |                | <b>Direct Entry, Direct to Crushed Stone</b> |

**Summary for Subcatchment 3S: Proposed WSD A-2 - Direct to Mount Pleasant Road**

Runoff = 0.28 cfs @ 12.29 hrs, Volume= 0.037 af, Depth= 0.59"

Runoff by SCS TR-20 method, UH=SCS, Time Span= 0.00-72.00 hrs, dt= 0.01 hrs  
 Type III 24-hr 2 Year Rainfall=3.35"

| Area (ac) | CN | Description                    |
|-----------|----|--------------------------------|
| 0.370     | 58 | Woods/grass comb., Good, HSG B |
| 0.250     | 61 | >75% Grass cover, Good, HSG B  |
| * 0.140   | 82 | Baseball Field, HSG B          |
| 0.760     | 63 | Weighted Average               |
| 0.760     |    | 100.00% Pervious Area          |

| Tc (min) | Length (feet) | Slope (ft/ft) | Velocity (ft/sec) | Capacity (cfs) | Description                          |
|----------|---------------|---------------|-------------------|----------------|--------------------------------------|
| 10.5     | 50            | 0.0040        | 0.08              |                | <b>Sheet Flow, AB</b>                |
|          |               |               |                   |                | Grass: Short n= 0.150 P2= 3.35"      |
| 6.1      | 302           | 0.0030        | 0.82              |                | <b>Shallow Concentrated Flow, BC</b> |
|          |               |               |                   |                | Grassed Waterway Kv= 15.0 fps        |
| 16.6     | 352           | Total         |                   |                |                                      |

**Summary for Pond 4P: Crushed Stone Infiltration Area**

Inflow Area = 0.790 ac, 63.29% Impervious, Inflow Depth = 1.89" for 2 Year event  
 Inflow = 2.14 cfs @ 12.00 hrs, Volume= 0.124 af  
 Outflow = 0.71 cfs @ 12.23 hrs, Volume= 0.124 af, Atten= 67%, Lag= 14.0 min  
 Discarded = 0.71 cfs @ 12.23 hrs, Volume= 0.124 af  
 Primary = 0.00 cfs @ 0.00 hrs, Volume= 0.000 af

Routing by Stor-Ind method, Time Span= 0.00-72.00 hrs, dt= 0.01 hrs  
 Peak Elev= 18.58' @ 12.23 hrs Surf.Area= 21,000 sf Storage= 679 cf

Plug-Flow detention time= 4.9 min calculated for 0.124 af (100% of inflow)  
 Center-of-Mass det. time= 4.9 min ( 823.4 - 818.5 )

| Volume | Invert | Avail.Storage | Storage Description  |
|--------|--------|---------------|--|
| #1     | 19.00' | 2,100 cf      | <b>150.00'W x 140.00'L x 0.10'H Crushed Stone Surface</b>  |
| #2     | 18.50' | 4,200 cf      | <b>150.00'W x 140.00'L x 0.50'H Crushed Stone Infiltration Area</b><br>10,500 cf Overall x 40.0% Voids |
|        |        | 6,300 cf      | Total Available Storage  |

| Device | Routing   | Invert | Outlet Devices  |
|--------|-----------|--------|---|
| #1     | Discarded | 18.50' | <b>1.430 in/hr Exfiltration over Surface area</b><br>Conductivity to Groundwater Elevation = 14.67' |
| #2     | Primary   | 19.00' | <b>290.0' long Sharp-Crested Vee/Trap Weir</b> Cv= 2.62 (C= 3.28)                                   |

**Discarded OutFlow** Max=0.71 cfs @ 12.23 hrs HW=18.58' (Free Discharge)  
 ↑1=Exfiltration ( Controls 0.71 cfs)

**Primary OutFlow** Max=0.00 cfs @ 0.00 hrs HW=18.50' (Free Discharge)  
 ↑2=Sharp-Crested Vee/Trap Weir ( Controls 0.00 cfs)

**Stage-Area-Storage for Pond 4P: Crushed Stone Infiltration Area**

| Elevation<br>(feet) | Surface<br>(sq-ft) | Storage<br>(cubic-feet) | Elevation<br>(feet) | Surface<br>(sq-ft) | Storage<br>(cubic-feet) |
|---------------------|--------------------|-------------------------|---------------------|--------------------|-------------------------|
| 18.50               | 21,000             | 0                       | 19.02               | 42,000             | 4,620                   |
| 18.51               | 21,000             | 84                      | 19.03               | 42,000             | 4,830                   |
| 18.52               | 21,000             | 168                     | 19.04               | 42,000             | 5,040                   |
| 18.53               | 21,000             | 252                     | 19.05               | 42,000             | 5,250                   |
| 18.54               | 21,000             | 336                     | 19.06               | 42,000             | 5,460                   |
| 18.55               | 21,000             | 420                     | 19.07               | 42,000             | 5,670                   |
| 18.56               | 21,000             | 504                     | 19.08               | 42,000             | 5,880                   |
| 18.57               | 21,000             | 588                     | 19.09               | 42,000             | 6,090                   |
| 18.58               | 21,000             | 672                     | 19.10               | 42,000             | <b>6,300</b>            |
| 18.59               | 21,000             | 756                     |                     |                    |                         |
| 18.60               | 21,000             | 840                     |                     |                    |                         |
| 18.61               | 21,000             | 924                     |                     |                    |                         |
| 18.62               | 21,000             | 1,008                   |                     |                    |                         |
| 18.63               | 21,000             | 1,092                   |                     |                    |                         |
| 18.64               | 21,000             | 1,176                   |                     |                    |                         |
| 18.65               | 21,000             | 1,260                   |                     |                    |                         |
| 18.66               | 21,000             | 1,344                   |                     |                    |                         |
| 18.67               | 21,000             | 1,428                   |                     |                    |                         |
| 18.68               | 21,000             | 1,512                   |                     |                    |                         |
| 18.69               | 21,000             | 1,596                   |                     |                    |                         |
| 18.70               | 21,000             | 1,680                   |                     |                    |                         |
| 18.71               | 21,000             | 1,764                   |                     |                    |                         |
| 18.72               | 21,000             | 1,848                   |                     |                    |                         |
| 18.73               | 21,000             | 1,932                   |                     |                    |                         |
| 18.74               | 21,000             | 2,016                   |                     |                    |                         |
| 18.75               | 21,000             | 2,100                   |                     |                    |                         |
| 18.76               | 21,000             | 2,184                   |                     |                    |                         |
| 18.77               | 21,000             | 2,268                   |                     |                    |                         |
| 18.78               | 21,000             | 2,352                   |                     |                    |                         |
| 18.79               | 21,000             | 2,436                   |                     |                    |                         |
| 18.80               | 21,000             | 2,520                   |                     |                    |                         |
| 18.81               | 21,000             | 2,604                   |                     |                    |                         |
| 18.82               | 21,000             | 2,688                   |                     |                    |                         |
| 18.83               | 21,000             | 2,772                   |                     |                    |                         |
| 18.84               | 21,000             | 2,856                   |                     |                    |                         |
| 18.85               | 21,000             | 2,940                   |                     |                    |                         |
| 18.86               | 21,000             | 3,024                   |                     |                    |                         |
| 18.87               | 21,000             | 3,108                   |                     |                    |                         |
| 18.88               | 21,000             | 3,192                   |                     |                    |                         |
| 18.89               | 21,000             | 3,276                   |                     |                    |                         |
| 18.90               | 21,000             | 3,360                   |                     |                    |                         |
| 18.91               | 21,000             | 3,444                   |                     |                    |                         |
| 18.92               | 21,000             | 3,528                   |                     |                    |                         |
| 18.93               | 21,000             | 3,612                   |                     |                    |                         |
| 18.94               | 21,000             | 3,696                   |                     |                    |                         |
| 18.95               | 21,000             | 3,780                   |                     |                    |                         |
| 18.96               | 21,000             | 3,864                   |                     |                    |                         |
| 18.97               | 21,000             | 3,948                   |                     |                    |                         |
| 18.98               | 21,000             | 4,032                   |                     |                    |                         |
| 18.99               | 21,000             | 4,116                   |                     |                    |                         |
| 19.00               | <b>42,000</b>      | 4,200                   |                     |                    |                         |
| 19.01               | 42,000             | 4,410                   |                     |                    |                         |

**2014.10.17 HydroCAD**

Prepared by W&C

HydroCAD® 10.00 s/n 01204 © 2012 HydroCAD Software Solutions LLC

---

*Type III 24-hr 2 Year Rainfall=3.35"*

Printed 10/17/2014

### **Summary for Link 5L: Proposed WSD A - To Mount Pleasant Road**

Inflow Area = 1.550 ac, 32.26% Impervious, Inflow Depth = 0.29" for 2 Year event  
Inflow = 0.28 cfs @ 12.29 hrs, Volume= 0.037 af  
Primary = 0.28 cfs @ 12.29 hrs, Volume= 0.037 af, Atten= 0%, Lag= 0.0 min

Primary outflow = Inflow, Time Span= 0.00-72.00 hrs, dt= 0.01 hrs



**2014.10.17 HydroCAD**

Prepared by W&C

HydroCAD® 10.00 s/n 01204 © 2012 HydroCAD Software Solutions LLC

Type III 24-hr 10 Year Rainfall=5.21"

Printed 10/17/2014

Time span=0.00-72.00 hrs, dt=0.01 hrs, 7201 points

Runoff by SCS TR-20 method, UH=SCS

Reach routing by Stor-Ind+Trans method - Pond routing by Stor-Ind method

**Subcatchment 2S: Proposed WSD A-1 - To** Runoff Area=0.790 ac 63.29% Impervious Runoff Depth=3.56"  
Tc=0.0 min CN=85 Runoff=3.99 cfs 0.235 af

**Subcatchment 3S: Proposed WSD A-2 -** Runoff Area=0.760 ac 0.00% Impervious Runoff Depth=1.64"  
Flow Length=352' Tc=16.6 min CN=63 Runoff=0.99 cfs 0.104 af

**Pond 4P: Crushed Stone Infiltration Area** Peak Elev=18.79' Storage=2,396 cf Inflow=3.99 cfs 0.235 af  
Discarded=0.75 cfs 0.235 af Primary=0.00 cfs 0.000 af Outflow=0.75 cfs 0.235 af

**Link 5L: Proposed WSD A - To Mount Pleasant Road** Inflow=0.99 cfs 0.104 af  
Primary=0.99 cfs 0.104 af

**Total Runoff Area = 1.550 ac Runoff Volume = 0.339 af Average Runoff Depth = 2.62"**  
**67.74% Pervious = 1.050 ac 32.26% Impervious = 0.500 ac**

**2014.10.17 HydroCAD**

Prepared by W&amp;C

HydroCAD® 10.00 s/n 01204 © 2012 HydroCAD Software Solutions LLC

Type III 24-hr 10 Year Rainfall=5.21"

Printed 10/17/2014

**Summary for Subcatchment 2S: Proposed WSD A-1 - To Proposed Infiltration Area**

Runoff = 3.99 cfs @ 12.00 hrs, Volume= 0.235 af, Depth= 3.56"

Runoff by SCS TR-20 method, UH=SCS, Time Span= 0.00-72.00 hrs, dt= 0.01 hrs  
Type III 24-hr 10 Year Rainfall=5.21"

| Area (ac) | CN | Description                    |
|-----------|----|--------------------------------|
| * 0.500   | 98 | Crushed stone, HSG B           |
| 0.190     | 61 | >75% Grass cover, Good, HSG B  |
| * 0.030   | 82 | Baseball Field, HSG B          |
| 0.070     | 58 | Woods/grass comb., Good, HSG B |
| 0.790     | 85 | Weighted Average               |
| 0.290     |    | 36.71% Pervious Area           |
| 0.500     |    | 63.29% Impervious Area         |

| Tc (min) | Length (feet) | Slope (ft/ft) | Velocity (ft/sec) | Capacity (cfs) | Description                                  |
|----------|---------------|---------------|-------------------|----------------|--|
| 0.0      |               |               |                   |                | <b>Direct Entry, Direct to Crushed Stone</b> |

**Summary for Subcatchment 3S: Proposed WSD A-2 - Direct to Mount Pleasant Road**

Runoff = 0.99 cfs @ 12.25 hrs, Volume= 0.104 af, Depth= 1.64"

Runoff by SCS TR-20 method, UH=SCS, Time Span= 0.00-72.00 hrs, dt= 0.01 hrs  
 Type III 24-hr 10 Year Rainfall=5.21"

| Area (ac) | CN | Description                    |
|-----------|----|--------------------------------|
| 0.370     | 58 | Woods/grass comb., Good, HSG B |
| 0.250     | 61 | >75% Grass cover, Good, HSG B  |
| * 0.140   | 82 | Baseball Field, HSG B          |
| 0.760     | 63 | Weighted Average               |
| 0.760     |    | 100.00% Pervious Area          |

| Tc (min) | Length (feet) | Slope (ft/ft) | Velocity (ft/sec) | Capacity (cfs) | Description                          |
|----------|---------------|---------------|-------------------|----------------|--------------------------------------|
| 10.5     | 50            | 0.0040        | 0.08              |                | <b>Sheet Flow, AB</b>                |
|          |               |               |                   |                | Grass: Short n= 0.150 P2= 3.35"      |
| 6.1      | 302           | 0.0030        | 0.82              |                | <b>Shallow Concentrated Flow, BC</b> |
|          |               |               |                   |                | Grassed Waterway Kv= 15.0 fps        |
| 16.6     | 352           | Total         |                   |                |                                      |

**Summary for Pond 4P: Crushed Stone Infiltration Area**

Inflow Area = 0.790 ac, 63.29% Impervious, Inflow Depth = 3.56" for 10 Year event  
 Inflow = 3.99 cfs @ 12.00 hrs, Volume= 0.235 af  
 Outflow = 0.75 cfs @ 12.40 hrs, Volume= 0.235 af, Atten= 81%, Lag= 24.0 min  
 Discarded = 0.75 cfs @ 12.40 hrs, Volume= 0.235 af  
 Primary = 0.00 cfs @ 0.00 hrs, Volume= 0.000 af

Routing by Stor-Ind method, Time Span= 0.00-72.00 hrs, dt= 0.01 hrs  
 Peak Elev= 18.79' @ 12.40 hrs Surf.Area= 21,000 sf Storage= 2,396 cf

Plug-Flow detention time= 17.9 min calculated for 0.235 af (100% of inflow)  
 Center-of-Mass det. time= 17.9 min ( 818.3 - 800.4 )

| Volume | Invert | Avail.Storage | Storage Description  |
|--------|--------|---------------|--|
| #1     | 19.00' | 2,100 cf      | <b>150.00'W x 140.00'L x 0.10'H Crushed Stone Surface</b>  |
| #2     | 18.50' | 4,200 cf      | <b>150.00'W x 140.00'L x 0.50'H Crushed Stone Infiltration Area</b><br>10,500 cf Overall x 40.0% Voids |
|        |        | 6,300 cf      | Total Available Storage  |

| Device | Routing   | Invert | Outlet Devices  |
|--------|-----------|--------|---|
| #1     | Discarded | 18.50' | <b>1.430 in/hr Exfiltration over Surface area</b><br>Conductivity to Groundwater Elevation = 14.67' |
| #2     | Primary   | 19.00' | <b>290.0' long Sharp-Crested Vee/Trap Weir</b> Cv= 2.62 (C= 3.28)                                   |

**Discarded OutFlow** Max=0.75 cfs @ 12.40 hrs HW=18.79' (Free Discharge)  
 ↑1=Exfiltration ( Controls 0.75 cfs)

**Primary OutFlow** Max=0.00 cfs @ 0.00 hrs HW=18.50' (Free Discharge)  
 ↑2=Sharp-Crested Vee/Trap Weir ( Controls 0.00 cfs)

**Stage-Area-Storage for Pond 4P: Crushed Stone Infiltration Area**

| Elevation<br>(feet) | Surface<br>(sq-ft) | Storage<br>(cubic-feet) | Elevation<br>(feet) | Surface<br>(sq-ft) | Storage<br>(cubic-feet) |
|---------------------|--------------------|-------------------------|---------------------|--------------------|-------------------------|
| 18.50               | 21,000             | 0                       | 19.02               | 42,000             | 4,620                   |
| 18.51               | 21,000             | 84                      | 19.03               | 42,000             | 4,830                   |
| 18.52               | 21,000             | 168                     | 19.04               | 42,000             | 5,040                   |
| 18.53               | 21,000             | 252                     | 19.05               | 42,000             | 5,250                   |
| 18.54               | 21,000             | 336                     | 19.06               | 42,000             | 5,460                   |
| 18.55               | 21,000             | 420                     | 19.07               | 42,000             | 5,670                   |
| 18.56               | 21,000             | 504                     | 19.08               | 42,000             | 5,880                   |
| 18.57               | 21,000             | 588                     | 19.09               | 42,000             | 6,090                   |
| 18.58               | 21,000             | 672                     | 19.10               | 42,000             | <b>6,300</b>            |
| 18.59               | 21,000             | 756                     |                     |                    |                         |
| 18.60               | 21,000             | 840                     |                     |                    |                         |
| 18.61               | 21,000             | 924                     |                     |                    |                         |
| 18.62               | 21,000             | 1,008                   |                     |                    |                         |
| 18.63               | 21,000             | 1,092                   |                     |                    |                         |
| 18.64               | 21,000             | 1,176                   |                     |                    |                         |
| 18.65               | 21,000             | 1,260                   |                     |                    |                         |
| 18.66               | 21,000             | 1,344                   |                     |                    |                         |
| 18.67               | 21,000             | 1,428                   |                     |                    |                         |
| 18.68               | 21,000             | 1,512                   |                     |                    |                         |
| 18.69               | 21,000             | 1,596                   |                     |                    |                         |
| 18.70               | 21,000             | 1,680                   |                     |                    |                         |
| 18.71               | 21,000             | 1,764                   |                     |                    |                         |
| 18.72               | 21,000             | 1,848                   |                     |                    |                         |
| 18.73               | 21,000             | 1,932                   |                     |                    |                         |
| 18.74               | 21,000             | 2,016                   |                     |                    |                         |
| 18.75               | 21,000             | 2,100                   |                     |                    |                         |
| 18.76               | 21,000             | 2,184                   |                     |                    |                         |
| 18.77               | 21,000             | 2,268                   |                     |                    |                         |
| 18.78               | 21,000             | 2,352                   |                     |                    |                         |
| 18.79               | 21,000             | 2,436                   |                     |                    |                         |
| 18.80               | 21,000             | 2,520                   |                     |                    |                         |
| 18.81               | 21,000             | 2,604                   |                     |                    |                         |
| 18.82               | 21,000             | 2,688                   |                     |                    |                         |
| 18.83               | 21,000             | 2,772                   |                     |                    |                         |
| 18.84               | 21,000             | 2,856                   |                     |                    |                         |
| 18.85               | 21,000             | 2,940                   |                     |                    |                         |
| 18.86               | 21,000             | 3,024                   |                     |                    |                         |
| 18.87               | 21,000             | 3,108                   |                     |                    |                         |
| 18.88               | 21,000             | 3,192                   |                     |                    |                         |
| 18.89               | 21,000             | 3,276                   |                     |                    |                         |
| 18.90               | 21,000             | 3,360                   |                     |                    |                         |
| 18.91               | 21,000             | 3,444                   |                     |                    |                         |
| 18.92               | 21,000             | 3,528                   |                     |                    |                         |
| 18.93               | 21,000             | 3,612                   |                     |                    |                         |
| 18.94               | 21,000             | 3,696                   |                     |                    |                         |
| 18.95               | 21,000             | 3,780                   |                     |                    |                         |
| 18.96               | 21,000             | 3,864                   |                     |                    |                         |
| 18.97               | 21,000             | 3,948                   |                     |                    |                         |
| 18.98               | 21,000             | 4,032                   |                     |                    |                         |
| 18.99               | 21,000             | 4,116                   |                     |                    |                         |
| 19.00               | <b>42,000</b>      | 4,200                   |                     |                    |                         |
| 19.01               | 42,000             | 4,410                   |                     |                    |                         |

**Summary for Link 5L: Proposed WSD A - To Mount Pleasant Road**

Inflow Area = 1.550 ac, 32.26% Impervious, Inflow Depth = 0.81" for 10 Year event  
Inflow = 0.99 cfs @ 12.25 hrs, Volume= 0.104 af  
Primary = 0.99 cfs @ 12.25 hrs, Volume= 0.104 af, Atten= 0%, Lag= 0.0 min

Primary outflow = Inflow, Time Span= 0.00-72.00 hrs, dt= 0.01 hrs

**2014.10.17 HydroCAD**

Type III 24-hr 100 Year Rainfall=9.00"

Prepared by W&C

Printed 10/17/2014

HydroCAD® 10.00 s/n 01204 © 2012 HydroCAD Software Solutions LLC

---

Time span=0.00-72.00 hrs, dt=0.01 hrs, 7201 points

Runoff by SCS TR-20 method, UH=SCS

Reach routing by Stor-Ind+Trans method - Pond routing by Stor-Ind method

**Subcatchment 2S: Proposed WSD A-1 - To** Runoff Area=0.790 ac 63.29% Impervious Runoff Depth=7.18"  
Tc=0.0 min CN=85 Runoff=7.78 cfs 0.473 af

**Subcatchment 3S: Proposed WSD A-2 -** Runoff Area=0.760 ac 0.00% Impervious Runoff Depth=4.47"  
Flow Length=352' Tc=16.6 min CN=63 Runoff=2.89 cfs 0.283 af

**Pond 4P: Crushed Stone Infiltration Area** Peak Elev=19.02' Storage=4,560 cf Inflow=7.78 cfs 0.473 af  
Discarded=1.49 cfs 0.439 af Primary=2.15 cfs 0.034 af Outflow=3.63 cfs 0.473 af

**Link 5L: Proposed WSD A - To Mount Pleasant Road** Inflow=4.15 cfs 0.317 af  
Primary=4.15 cfs 0.317 af

**Total Runoff Area = 1.550 ac Runoff Volume = 0.756 af Average Runoff Depth = 5.85"**  
**67.74% Pervious = 1.050 ac 32.26% Impervious = 0.500 ac**

**Summary for Subcatchment 2S: Proposed WSD A-1 - To Proposed Infiltration Area**

Runoff = 7.78 cfs @ 12.00 hrs, Volume= 0.473 af, Depth= 7.18"

Runoff by SCS TR-20 method, UH=SCS, Time Span= 0.00-72.00 hrs, dt= 0.01 hrs  
 Type III 24-hr 100 Year Rainfall=9.00"

| Area (ac) | CN | Description                    |
|-----------|----|--------------------------------|
| * 0.500   | 98 | Crushed stone, HSG B           |
| 0.190     | 61 | >75% Grass cover, Good, HSG B  |
| * 0.030   | 82 | Baseball Field, HSG B          |
| 0.070     | 58 | Woods/grass comb., Good, HSG B |
| 0.790     | 85 | Weighted Average               |
| 0.290     |    | 36.71% Pervious Area           |
| 0.500     |    | 63.29% Impervious Area         |

| Tc (min) | Length (feet) | Slope (ft/ft) | Velocity (ft/sec) | Capacity (cfs) | Description                                  |
|----------|---------------|---------------|-------------------|----------------|--|
| 0.0      |               |               |                   |                | <b>Direct Entry, Direct to Crushed Stone</b> |



**Summary for Subcatchment 3S: Proposed WSD A-2 - Direct to Mount Pleasant Road**

Runoff = 2.89 cfs @ 12.23 hrs, Volume= 0.283 af, Depth= 4.47"

Runoff by SCS TR-20 method, UH=SCS, Time Span= 0.00-72.00 hrs, dt= 0.01 hrs  
 Type III 24-hr 100 Year Rainfall=9.00"

| Area (ac) | CN | Description                    |
|-----------|----|--------------------------------|
| 0.370     | 58 | Woods/grass comb., Good, HSG B |
| 0.250     | 61 | >75% Grass cover, Good, HSG B  |
| * 0.140   | 82 | Baseball Field, HSG B          |
| 0.760     | 63 | Weighted Average               |
| 0.760     |    | 100.00% Pervious Area          |

| Tc (min) | Length (feet) | Slope (ft/ft) | Velocity (ft/sec) | Capacity (cfs) | Description                          |
|----------|---------------|---------------|-------------------|----------------|--------------------------------------|
| 10.5     | 50            | 0.0040        | 0.08              |                | <b>Sheet Flow, AB</b>                |
|          |               |               |                   |                | Grass: Short n= 0.150 P2= 3.35"      |
| 6.1      | 302           | 0.0030        | 0.82              |                | <b>Shallow Concentrated Flow, BC</b> |
|          |               |               |                   |                | Grassed Waterway Kv= 15.0 fps        |
| 16.6     | 352           | Total         |                   |                |                                      |

**Summary for Pond 4P: Crushed Stone Infiltration Area**

Inflow Area = 0.790 ac, 63.29% Impervious, Inflow Depth = 7.18" for 100 Year event  
 Inflow = 7.78 cfs @ 12.00 hrs, Volume= 0.473 af  
 Outflow = 3.63 cfs @ 12.09 hrs, Volume= 0.473 af, Atten= 53%, Lag= 5.4 min  
 Discarded = 1.49 cfs @ 12.09 hrs, Volume= 0.439 af  
 Primary = 2.15 cfs @ 12.09 hrs, Volume= 0.034 af

Routing by Stor-Ind method, Time Span= 0.00-72.00 hrs, dt= 0.01 hrs  
 Peak Elev= 19.02' @ 12.09 hrs Surf.Area= 42,000 sf Storage= 4,560 cf

Plug-Flow detention time= 30.5 min calculated for 0.473 af (100% of inflow)  
 Center-of-Mass det. time= 30.5 min ( 811.5 - 781.0 )

| Volume | Invert | Avail.Storage | Storage Description  |
|--------|--------|---------------|--|
| #1     | 19.00' | 2,100 cf      | <b>150.00'W x 140.00'L x 0.10'H Crushed Stone Surface</b>  |
| #2     | 18.50' | 4,200 cf      | <b>150.00'W x 140.00'L x 0.50'H Crushed Stone Infiltration Area</b><br>10,500 cf Overall x 40.0% Voids |
|        |        | 6,300 cf      | Total Available Storage  |

| Device | Routing   | Invert | Outlet Devices  |
|--------|-----------|--------|---|
| #1     | Discarded | 18.50' | <b>1.430 in/hr Exfiltration over Surface area</b><br>Conductivity to Groundwater Elevation = 14.67' |
| #2     | Primary   | 19.00' | <b>290.0' long Sharp-Crested Vee/Trap Weir</b> Cv= 2.62 (C= 3.28)                                   |

**Discarded OutFlow** Max=1.49 cfs @ 12.09 hrs HW=19.02' (Free Discharge)  
 ↑1=Exfiltration ( Controls 1.49 cfs)

**Primary OutFlow** Max=2.13 cfs @ 12.09 hrs HW=19.02' (Free Discharge)  
 ↑2=Sharp-Crested Vee/Trap Weir (Weir Controls 2.13 cfs @ 0.43 fps)

**Stage-Area-Storage for Pond 4P: Crushed Stone Infiltration Area**

| Elevation<br>(feet) | Surface<br>(sq-ft) | Storage<br>(cubic-feet) | Elevation<br>(feet) | Surface<br>(sq-ft) | Storage<br>(cubic-feet) |
|---------------------|--------------------|-------------------------|---------------------|--------------------|-------------------------|
| 18.50               | 21,000             | 0                       | 19.02               | 42,000             | 4,620                   |
| 18.51               | 21,000             | 84                      | 19.03               | 42,000             | 4,830                   |
| 18.52               | 21,000             | 168                     | 19.04               | 42,000             | 5,040                   |
| 18.53               | 21,000             | 252                     | 19.05               | 42,000             | 5,250                   |
| 18.54               | 21,000             | 336                     | 19.06               | 42,000             | 5,460                   |
| 18.55               | 21,000             | 420                     | 19.07               | 42,000             | 5,670                   |
| 18.56               | 21,000             | 504                     | 19.08               | 42,000             | 5,880                   |
| 18.57               | 21,000             | 588                     | 19.09               | 42,000             | 6,090                   |
| 18.58               | 21,000             | 672                     | 19.10               | 42,000             | <b>6,300</b>            |
| 18.59               | 21,000             | 756                     |                     |                    |                         |
| 18.60               | 21,000             | 840                     |                     |                    |                         |
| 18.61               | 21,000             | 924                     |                     |                    |                         |
| 18.62               | 21,000             | 1,008                   |                     |                    |                         |
| 18.63               | 21,000             | 1,092                   |                     |                    |                         |
| 18.64               | 21,000             | 1,176                   |                     |                    |                         |
| 18.65               | 21,000             | 1,260                   |                     |                    |                         |
| 18.66               | 21,000             | 1,344                   |                     |                    |                         |
| 18.67               | 21,000             | 1,428                   |                     |                    |                         |
| 18.68               | 21,000             | 1,512                   |                     |                    |                         |
| 18.69               | 21,000             | 1,596                   |                     |                    |                         |
| 18.70               | 21,000             | 1,680                   |                     |                    |                         |
| 18.71               | 21,000             | 1,764                   |                     |                    |                         |
| 18.72               | 21,000             | 1,848                   |                     |                    |                         |
| 18.73               | 21,000             | 1,932                   |                     |                    |                         |
| 18.74               | 21,000             | 2,016                   |                     |                    |                         |
| 18.75               | 21,000             | 2,100                   |                     |                    |                         |
| 18.76               | 21,000             | 2,184                   |                     |                    |                         |
| 18.77               | 21,000             | 2,268                   |                     |                    |                         |
| 18.78               | 21,000             | 2,352                   |                     |                    |                         |
| 18.79               | 21,000             | 2,436                   |                     |                    |                         |
| 18.80               | 21,000             | 2,520                   |                     |                    |                         |
| 18.81               | 21,000             | 2,604                   |                     |                    |                         |
| 18.82               | 21,000             | 2,688                   |                     |                    |                         |
| 18.83               | 21,000             | 2,772                   |                     |                    |                         |
| 18.84               | 21,000             | 2,856                   |                     |                    |                         |
| 18.85               | 21,000             | 2,940                   |                     |                    |                         |
| 18.86               | 21,000             | 3,024                   |                     |                    |                         |
| 18.87               | 21,000             | 3,108                   |                     |                    |                         |
| 18.88               | 21,000             | 3,192                   |                     |                    |                         |
| 18.89               | 21,000             | 3,276                   |                     |                    |                         |
| 18.90               | 21,000             | 3,360                   |                     |                    |                         |
| 18.91               | 21,000             | 3,444                   |                     |                    |                         |
| 18.92               | 21,000             | 3,528                   |                     |                    |                         |
| 18.93               | 21,000             | 3,612                   |                     |                    |                         |
| 18.94               | 21,000             | 3,696                   |                     |                    |                         |
| 18.95               | 21,000             | 3,780                   |                     |                    |                         |
| 18.96               | 21,000             | 3,864                   |                     |                    |                         |
| 18.97               | 21,000             | 3,948                   |                     |                    |                         |
| 18.98               | 21,000             | 4,032                   |                     |                    |                         |
| 18.99               | 21,000             | 4,116                   |                     |                    |                         |
| 19.00               | <b>42,000</b>      | 4,200                   |                     |                    |                         |
| 19.01               | 42,000             | 4,410                   |                     |                    |                         |

**Summary for Link 5L: Proposed WSD A - To Mount Pleasant Road**

Inflow Area = 1.550 ac, 32.26% Impervious, Inflow Depth = 2.45" for 100 Year event  
Inflow = 4.15 cfs @ 12.19 hrs, Volume= 0.317 af  
Primary = 4.15 cfs @ 12.19 hrs, Volume= 0.317 af, Atten= 0%, Lag= 0.0 min

Primary outflow = Inflow, Time Span= 0.00-72.00 hrs, dt= 0.01 hrs

## **APPENDIX F : GROUNDWATER MOUNDING ANALYSIS AND SYSTEM DRAWDOWN TIME CALCULATION**

### **6 Inch Crushed Stone Infiltration Area**

Volume calculations for the proposed 6 Inch Crushed Stone Infiltration Area are provided in Appendix E. The System drawdown time is calculated below. The calculations represent the drawdown time for the full storage volume provided, which exceeds the volume associated with the 100 year storm event.

#### **Drawdown within 72 hours:**

Stormwater within the System will infiltrate (drawdown) into the underlying soil. A permeability rate of 1.43 inches per hour was used based upon the soil permeability test results in Appendix C. A factor of safety of 2 was used per the Pinelands Commission CMP resulting in a drawdown time design permeability rate of 0.72 inches per hour.

Drawdown calculations are provided below.

$$T_D = Rv / (k \times \text{bottom area})$$

Where:  $T_D$  = Drawdown Time  
 $Rv$  = Storage Volume = 4,200 cf (Stone Volume)  
 $K$  = 0.72 in/hr  
Bottom Area = Bottom Area of Crushed Stone = 140' x 150' = 21,000 sf

#### **Infiltration Basin:**

$$T_D = (4,200 \text{ cf}) / [(0.72 \text{ in/hr}) (1' / 12'') (21,000 \text{ sf})]$$
$$T_D = \mathbf{3.33 \text{ Hours (3 Hours, 20 Minutes)}}$$

Designed By:     PJ     Date: 10-17-2014  
Checked By:            Date:           

**Groundwater Mounding Analysis Input Data**

Recharge Rate: 100 Year Storm, 24 Hour Exfiltration Volume = 0.439 ac-ft = 19,123 cf  
= (19,123 cf/day)/(150' x 140') = **0.91 ft/day**

Specific Yield: **0.25 (K3 Permeability Type Soil – Use Specific Yield for Sand)**

Horizontal Hydraulic Conductivity: Average Permeability Rate =  $1 \times 10^{-4}$  m/sec (Fine to Coarse Sand)  
= **28.3 ft/day**

½ Length of System = **75 ft**

½ Width of System = **70 ft**

Duration of Infiltration Time = Drawdown Time = 3.33 hours = **0.14 days**

Initial Thickness of Saturated Zone = 25 ft - (28" x (1'/12")) = **23 ft +/- (From Boring BS-3A)**

Note: See attached sheets for mounding calculation and reference material.

This spreadsheet will calculate the height of a groundwater mound beneath a stormwater infiltration basin. More information can be found in the U.S. Geological Survey Scientific Investigations Report 2010-5102 "Simulation of groundwater mounding beneath hypothetical stormwater infiltration basins".

The user must specify infiltration rate (R), specific yield (Sy), horizontal hydraulic conductivity (Kh), basin dimensions (x, y), duration of infiltration period (t), and the initial thickness of the saturated zone (hi(0), height of the water table if the bottom of the aquifer is the datum). For a square basin the half width equals the half length (x = y). For a rectangular basin, if the user wants the water-table changes perpendicular to the long side, specify x as the short dimension and y as the long dimension. Conversely, if the user wants the values perpendicular to the short side, specify y as the short dimension, x as the long dimension. All distances are from the center of the basin. Users can change the distances from the center of the basin at which water-table aquifer thickness are calculated.

Cells highlighted in yellow are values that can be changed by the user. Cells highlighted in red are output values based on user-specified inputs. **The user MUST click the blue "Re-Calculate Now" button each time ANY of the user-specified inputs are changed** otherwise necessary iterations to converge on the correct solution will not be done and values shown will be incorrect. Use consistent units for all input values (for example, feet and days)

| Input Values |         | use consistent units (e.g. feet & days <b>or</b> inches & hours)                            |           | Conversion Table |  |
|--------------|---------|---|-----------|------------------|--|
|              |         |   | inch/hour | feet/day         |  |
| 0.9100       | R       | Recharge (infiltration) rate (feet/day)   | 0.67      | 1.33             |  |
| 0.250        | Sy      | Specific yield, Sy (dimensionless, between 0 and 1)   |           |                  |  |
| 28.30        | K       | Horizontal hydraulic conductivity, Kh (feet/day)*   | 2.00      | 4.00             | In the report accompanying this spreadsheet (USGS SIR 2010-5102), vertical soil permeability (ft/d) is assumed to be one-tenth horizontal hydraulic conductivity (ft/d). |
| 75.000       | x       | 1/2 length of basin (x direction, in feet)  |           |                  |  |
| 70.000       | y       | 1/2 width of basin (y direction, in feet)   | hours     | days             |  |
| 0.140        | t       | duration of infiltration period (days)  | 36        | 1.50             |  |
| 23.000       | hi(0)   | initial thickness of saturated zone (feet)  |           |                  |  |
| 23.508       | h(max)  | maximum thickness of saturated zone (beneath center of basin at end of infiltration period) |           |                  |  |
| 0.508        | Δh(max) | maximum groundwater mounding (beneath center of basin at end of infiltration period)        |           |                  |  |

| Ground-water Mounding, in feet | Distance from center of basin in x direction, in feet |
|--------------------------------|---|
| 0.508                          | 0   |
| 0.506                          | 20  |
| 0.489                          | 40  |
| 0.412                          | 60  |
| 0.188                          | 80  |
| 0.045                          | 100   |
| 0.008                          | 120   |
| 0.001                          | 140   |
| 0.000                          | 160   |
| 0.000                          | 180   |



**Re-Calculate Now**

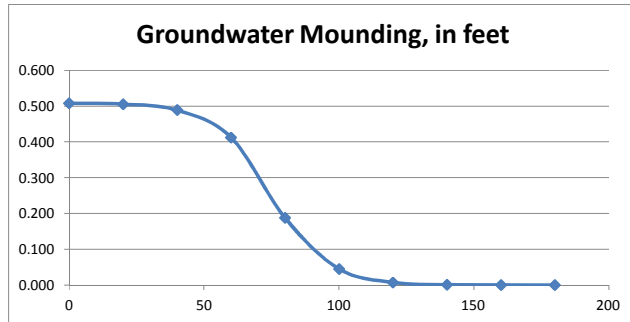

**Disclaimer**

This spreadsheet solving the Hantush (1967) equation for ground-water mounding beneath an infiltration basin is made available to the general public as a convenience for those wishing to replicate values documented in the USGS Scientific Investigations Report 2010-5102 "Groundwater mounding beneath hypothetical stormwater infiltration basins" or to calculate values based on user-specified site conditions. Any changes made to the spreadsheet (other than values identified as user-specified) after transmission from the USGS could have unintended, undesirable consequences. These consequences could include, but may not be limited to: erroneous output, numerical instabilities, and violations of underlying assumptions that are inherent in results presented in the accompanying USGS published report. The USGS assumes no responsibility for the consequences of any changes made to the spreadsheet. If changes are made to the spreadsheet, the user is responsible for documenting the changes and justifying the results and conclusions.



**Table 4-1** Approximate average porosity, specific yield, and permeability of various materials

| Material           | Porosity,<br>% | Specific yield,<br>% | Permeability $K_p$  |        | Intrinsic<br>permeability,<br>darcys |
|--------------------|----------------|----------------------|---------------------|--------|--------------------------------------|
|                    |                |                      | gpd/ft <sup>2</sup> | m/day  |                                      |
| Clay               | 45             | 3                    | 0.01                | 0.0004 | 0.0005                               |
| Sand               | 35             | 25                   | 1000                | 41     | 50                                   |
| Gravel             | 25             | 22                   | 100000              | 4100   | 5000                                 |
| Gravel and sand    | 20             | 16                   | 10000               | 410    | 500                                  |
| Sandstone          | 15             | 8                    | 100                 | 4.1    | 5                                    |
| Limestone, shale   | 5              | 2                    | 1                   | 0.041  | 0.05                                 |
| Quartzite, granite | 1              | 0.5                  | 0.01                | 0.0004 | 0.0005                               |

may yield almost all the water it contains. The most important aquifers economically are deposits of sand and gravel, which have a fairly high specific yield.

**4-4 The water table** The static level of water in wells penetrating the zone of saturation (Fig. 4-1) is called the *water table*. The water table is often described as a subdued replica of the surface topography. It is commonly higher under the hills than under valleys, and a contour map of the water table in an area may look much like the surface topography. The water table is the surface of a water body which is constantly adjusting itself toward an equilibrium condition. If there were no recharge to or outflow from the groundwater in a basin, the water table would eventually become horizontal. Few basins have uniform recharge conditions at the surface. Some areas receive more rain than others. Some portions of the basin have more permeable soil. Thus, when intermittent recharge does occur, mounds and ridges form in the water table under the areas of greatest recharge. Subsequent recharge creates additional mounds, perhaps at other points in the basin, and the flow pattern is further changed. Superimpose upon this fairly simple picture variations in permeability of the aquifers, impermeable strata, and the influence of lakes, streams, and wells, and one obtains a picture of a water table constantly adjusting toward equilibrium. Because of the low flow rates in most aquifers this equilibrium is rarely attained before additional disturbances occur.

When water occurs in cracks, fissures, and caverns, the situation is somewhat different. Flow in large openings is usually turbulent, and adjustments take place fairly rapidly. Water is usually found at about the same level anywhere within a system of interconnected openings. Water levels may vary considerably, however, between entirely separate openings in the same formation (Fig. 4-3). Wells driven into such formations will yield little water unless they intersect one of the fissures or caverns.

**4-5 Artesian aquifers** The discussion thus far has dealt with aquifers in which the upper surface of the water is unconfined. Sometimes an aquifer is confined by strata of low permeability (Fig. 4-4). Such *artesian aquifers* are analogous to

# WATER-RESOURCES ENGINEERING

THIRD EDITION

Ray K. Linsley

*Professor Emeritus of Hydraulic Engineering  
Stanford University  
Partner, Linsley, Kraeger Associates*

Joseph B. Franzini

*Professor of Civil Engineering  
Associate Chairman, Department of Civil Engineering  
Stanford University*

**McGraw-Hill Book Company**

New York St. Louis San Francisco Auckland Bogotá Düsseldorf  
Johannesburg London Madrid Mexico Montreal New Delhi Panama  
Paris São Paulo Singapore Sydney Tokyo Toronto

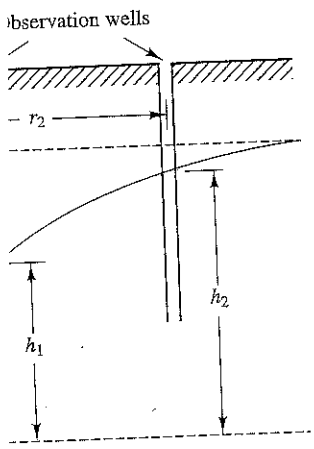

on of permeability coefficient in un-

$h_1$  and  $h_2$ , will reach final equilibrium values. observation wells are measured to calculate the

coefficient can be calculated by integrating Equa- observation wells to obtain

$$\frac{Q}{2\pi b} \ln \left( \frac{r_2}{r_1} \right) \quad (7.11)$$

coefficient can be calculated by integrating Equation observation wells to obtain

$$\frac{Q}{2\pi b} \ln \left( \frac{r_2}{r_1} \right) \quad (7.12)$$

in a confined aquifer, as shown in Figure 7.6.

Equations (7.11) and (7.12) assumes that the aquifer is *homo-* (*m*) and *isotropic* (permeability is independent over an area larger than the area that the radius however, the equations have been widely used to determine permeability coefficients for a variety of aquifer conditions.

Equation (7.11) is used to determine the coefficient of permeability for a range for the coefficient of permeability for

drawdown in a deep into the undisturbed water table of an unconfined aquifer at the constant rate of  $0.1 \text{ m}^3/\text{sec}$ , the drawdown

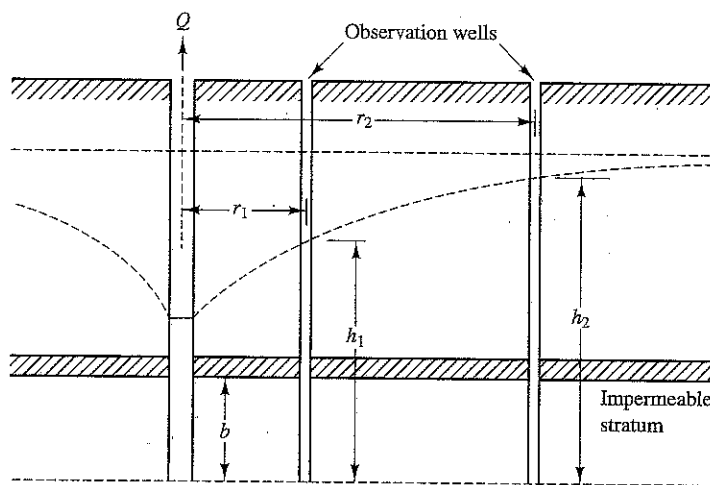

Figure 7.6 Field determination of permeability coefficient in confined aquifers.

TABLE 7.2 Magnitude of Coefficient of Permeability of Some Natural Soil Formations

| Soils             | $K(\text{m/sec})^*$ |
|-------------------|---------------------|
| Clays             | $<10^{-9}$          |
| Sandy clays       | $10^{-9} - 10^{-8}$ |
| Peat              | $10^{-9} - 10^{-7}$ |
| Silt              | $10^{-8} - 10^{-7}$ |
| Very fine sands   | $10^{-6} - 10^{-5}$ |
| Fine sands        | $10^{-5} - 10^{-4}$ |
| Coarse sands      | $10^{-4} - 10^{-2}$ |
| Sand with gravels | $10^{-3} - 10^{-2}$ |
| Gravels           | $>10^{-2}$          |

\* For  $K$  in (ft/sec), multiply by 3.31

at distances of 20 m and 50 m from the well are observed to be 4 m and 2.5 m, respectively. Determine the coefficient of permeability of the aquifer. What is the drawdown at the pumped well?

**Solution**

Conditions given are  $Q = 0.1 \text{ m}^3/\text{sec}$ ,  $r_1 = 20 \text{ m}$ ,  $r_2 = 50 \text{ m}$ ; hence,  $h_1 = 30.0 \text{ m} - 4 \text{ m} = 26 \text{ m}$ , and  $h_2 = 30.0 \text{ m} - 2.5 \text{ m} = 27.5 \text{ m}$ , in reference to Figures 7.4 and 7.5. Substituting these values into Equation (7.11), we have

$$K = \frac{0.1}{\pi(27.5^2 - 26^2)} \ln \left( \frac{50}{20} \right) = \frac{0.00114}{\pi} = 3.63 \times 10^{-4} \text{ m/sec}$$

The drawdown at the pumped well can be calculated by using the same equation with the calculated value of the coefficient of permeability and the well diameter.

FUNDAMENTALS OF  
**HYDRAULIC  
ENGINEERING  
SYSTEMS**

---

THIRD EDITION

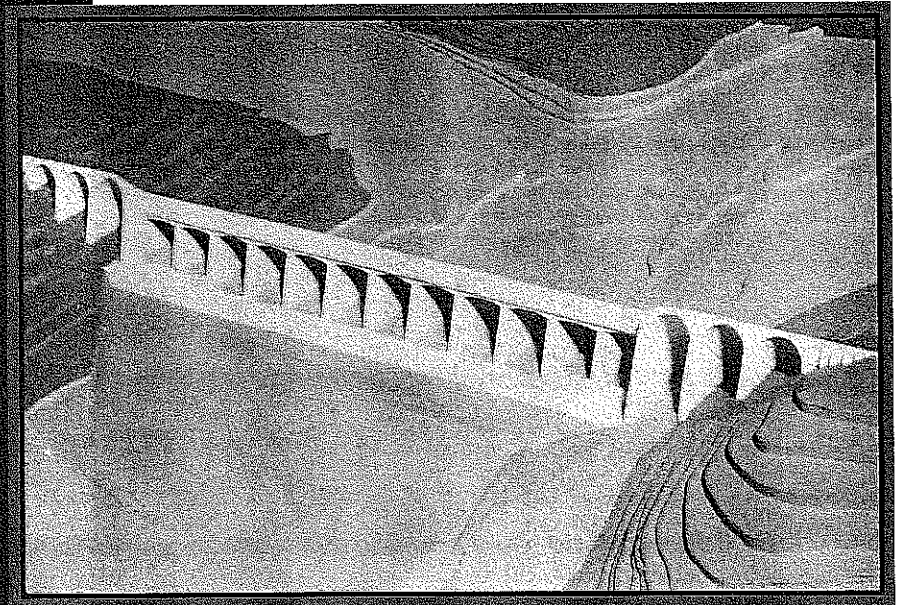

NED H. C. HWANG  
ROBERT J. HOUGHTALEN

# BORING LOG

# Boring # BS-3A

**Drilling Contractor:** TRC Solutions, Inc.  
**Drilling Rig Operator:** J. Dotzer  
**Drilling Method:** 3 1/4 inch HSA  
**Casing Size/Type:** /  
**Drilling Equipment:** Acker ATV Rig  
**CW Representative:** L. Clevenger  
**Dates: Started:** 12/20/2012  
**Completed:** 12/20/2012  
**Ground Surface Elevation (ft): ±** 20.2



**Project:** 24" BL Pipeline Supply Project  
**Project Number:** NJ-X-XX-124  
**Project Location:** Cumberland, Atlantic, and Cape May Counties, NJ  
**Boring Location:** See Test Boring Location Plan

| GROUNDWATER OBSERVATIONS |            | DEPTH (FEET) |
|--------------------------|------------|--------------|
| ▽ Encountered:           | 12/20/2012 | 4            |
| ▼ Completion:            |            |              |
| ▽ 24 Hour Reading:       |            |              |

| Depth (ft) | Soil Samples            |               |                              |         | Rock Core |         |         | Graphic Symbol | STRATUM   | MATERIAL DESCRIPTION | Elevation | Water Cont. (%)    | REMARKS |
|------------|-------------------------|---------------|------------------------------|---------|-----------|---------|---------|----------------|---|----------------------|-----------|--------------------|---------|
|            | Sample No.              | Recovery (ft) | Pen. Resist. (blows / 6 in.) | N Value | Run No.   | Rec (%) | RQD (%) |                |   |                      |           |                    |         |
| 6          | S1                      | 0.8           | 1-2-1-1                      | 3       |           |         |         | B              | 6 inches TOPSOIL.<br>Brown medium to fine SAND, trace fine Gravel, trace Silt. (SP) | ▽                    |           | Cohansey Formation |         |
| 8          | S2                      | 0.8           | WOH/24"                      | WOH     |           |         |         |                | Same.   |                      |           |                    |         |
| 10         | S3                      | 0.7           | 2-2-1-2                      | 3       |           |         |         |                | Orange brown coarse to fine SAND, trace fine Gravel, trace Silt. (SP)               |                      |           |                    |         |
| 12         | S4                      | 1.5           | 2-7-7-12                     | 14      |           |         |         |                | Light brown medium to fine SAND, trace Silt. (SP)                                   |                      |           |                    |         |
| 14         | S5                      | 1.5           | 8-12-11-16                   | 23      |           |         |         |                | Same.   |                      |           |                    |         |
| 16         |                         |               |                              |         |           |         |         |                |   |                      |           |                    |         |
| 18         | S6                      | 1.6           | 5-11-17-15                   | 28      |           |         |         |                | Same.   |                      |           |                    |         |
| 20         | S7                      | 1.8           | 10-12-9-7                    | 21      |           |         |         |                | Same.   |                      |           |                    |         |
| 22         |                         |               |                              |         |           |         |         |                |   |                      |           |                    |         |
| 24         | S8                      | 1.8           | 3-4-4-7                      | 8       |           |         |         | Same.          |   |                      |           |                    |         |
| 25         | Bottom of Boring at 25' |               |                              |         |           |         |         |                |   |                      |           |                    |         |

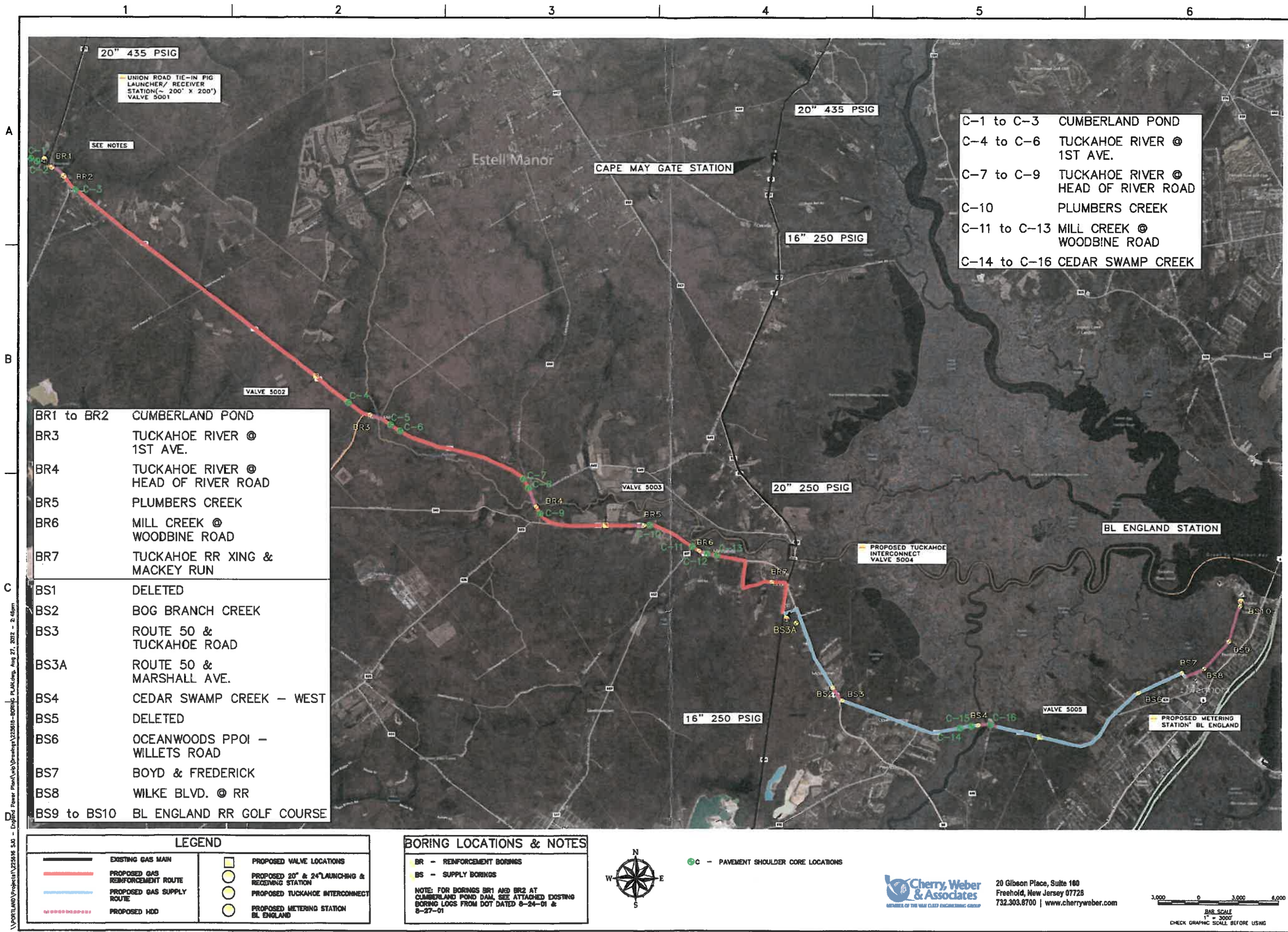

20" 435 PSIG  
UNION ROAD TIE-IN FIG LAUNCHER/ RECEIVER STATION (~ 200' X 200') VALVE 5001

SEE NOTES

CAPE MAY GATE STATION

20" 435 PSIG

16" 250 PSIG

C-1 to C-3 CUMBERLAND POND  
C-4 to C-6 TUCKAHOE RIVER @ 1ST AVE.  
C-7 to C-9 TUCKAHOE RIVER @ HEAD OF RIVER ROAD  
C-10 PLUMBERS CREEK  
C-11 to C-13 MILL CREEK @ WOODBINE ROAD  
C-14 to C-16 CEDAR SWAMP CREEK

VALVE 5002

BR1 to BR2 CUMBERLAND POND  
BR3 TUCKAHOE RIVER @ 1ST AVE.  
BR4 TUCKAHOE RIVER @ HEAD OF RIVER ROAD  
BR5 PLUMBERS CREEK  
BR6 MILL CREEK @ WOODBINE ROAD  
BR7 TUCKAHOE RR XING & MACKAY RUN

VALVE 5003

20" 250 PSIG

BL ENGLAND STATION

BS1 DELETED  
BS2 BOG BRANCH CREEK  
BS3 ROUTE 50 & TUCKAHOE ROAD  
BS3A ROUTE 50 & MARSHALL AVE.  
BS4 CEDAR SWAMP CREEK - WEST  
BS5 DELETED  
BS6 OCEANWOODS PPOI - WILLETS ROAD  
BS7 BOYD & FREDERICK  
BS8 WILKE BLVD. @ RR  
BS9 to BS10 BL ENGLAND RR GOLF COURSE

PROPOSED TUCKAHOE INTERCONNECT VALVE 5004

16" 250 PSIG

VALVE 5005

PROPOSED METERING STATION BL ENGLAND

LEGEND

|  |                                  |  |  |
|--|----------------------------------|--|--|
|  | EXISTING GAS MAIN                |  | PROPOSED VALVE LOCATIONS                         |
|  | PROPOSED GAS REINFORCEMENT ROUTE |  | PROPOSED 20" & 24" LAUNCHING & RECEIVING STATION |
|  | PROPOSED GAS SUPPLY ROUTE        |  | PROPOSED TUCKAHOE INTERCONNECT                   |
|  | PROPOSED HDD                     |  | PROPOSED METERING STATION BL ENGLAND             |

BORING LOCATIONS & NOTES

BR - REINFORCEMENT BORINGS  
BS - SUPPLY BORINGS  
C - PAVEMENT SHOULDER CORE LOCATIONS

NOTE: FOR BORINGS BR1 AND BR2 AT CUMBERLAND POND DAM, SEE ATTACHED EXISTING BORING LOGS FROM DOT DATED 6-24-01 & 8-27-01



20 Gibson Place, Suite 100  
Freehold, New Jersey 07728  
732.303.8700 | www.cherryweber.com

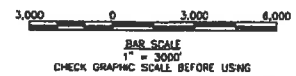

59 Millstone Road, Building 200  
East Windsor, New Jersey 08520  
877.788.8881 | www.woodwardclark.com

WOODWARD  
& CLARK

CONSULTANTS & ENGINEERS  
A DIVISION OF WOODWARD-CLARK INC. AND ITS CLIENTS  
REPRODUCTION OR MODIFICATION WITHOUT WRITTEN PERMISSION IS PROHIBITED.

| REV | DESCRIPTION | DATE |
|-----|-------------|------|
|     |             |      |
|     |             |      |
|     |             |      |
|     |             |      |

DESIGNED BY: [ ] CHECKED BY: [ ]  
DRAWN BY: [ ] DATE: [ ]

BORINGS PLAN & PAVEMENT CORE PLAN

SOUTH JERSEY GAS  
1 SOUTH JERSEY PLAZA  
FOLSOM, NJ 08037

B.L. ENGLAND POWER  
PLANT GAS SUPPLY

JOB NO.: 225615  
DATE: AUGUST 17, 2019  
SCALE: AS SHOWN

**Table 5-3 Design Infiltration Rates for Different Soil Textures (Rawls et al., 1982)**

| USDA Soil Texture | Design Infiltration Rate ( $f_c$ ) (in/hr) | Design Infiltration Rate ( $f_c$ ) (ft/min) |
|-------------------|--|---|
| Sand              | 8.27                                       | 0.0115                                      |
| Loamy Sand        | 2.41                                       | 0.0033                                      |
| Sandy Loam        | 1.02                                       | 0.0014                                      |
| Loam              | 0.52                                       | 0.0007                                      |
| Silt Loam         | 0.27                                       | 0.0004                                      |

## APPENDIX G : NOAA 24 HOUR RAINFALL DEPTHS





NOAA Atlas 14, Volume 2, Version 3  
 Location name: Woodbine, New Jersey, US\*  
 Coordinates: 39.2739, -74.7523  
 Elevation: 26ft\*  
 \* source: Google Maps



**POINT PRECIPITATION FREQUENCY ESTIMATES**

G.M. Bonnin, D. Martin, B. Lin, T. Parzybok, M. Yekta, and D. Riley

NOAA, National Weather Service, Silver Spring, Maryland

[PF tabular](#) | [PF graphical](#) | [Maps & aeriels](#)

**PF tabular**

| <b>PDS-based point precipitation frequency estimates with 90% confidence intervals (in inches)<sup>1</sup></b> |                                    |                        |                        |                        |                        |                        |                        |                        |                        |                        |
|--|------------------------------------|------------------------|------------------------|------------------------|------------------------|------------------------|------------------------|------------------------|------------------------|------------------------|
| Duration   | Average recurrence interval(years) |                        |                        |                        |                        |                        |                        |                        |                        |                        |
|  | 1                                  | 2                      | 5                      | 10                     | 25                     | 50                     | 100                    | 200                    | 500                    | 1000                   |
| 5-min  | 0.350<br>(0.314-0.390)             | 0.405<br>(0.363-0.449) | 0.455<br>(0.407-0.505) | 0.533<br>(0.477-0.591) | 0.599<br>(0.535-0.666) | 0.664<br>(0.590-0.739) | 0.718<br>(0.635-0.799) | 0.769<br>(0.675-0.858) | 0.823<br>(0.716-0.925) | 0.882<br>(0.759-0.996) |
| 10-min   | 0.559<br>(0.501-0.622)             | 0.647<br>(0.581-0.717) | 0.729<br>(0.652-0.809) | 0.852<br>(0.763-0.946) | 0.955<br>(0.852-1.06)  | 1.06<br>(0.940-1.18)   | 1.14<br>(1.01-1.27)    | 1.22<br>(1.07-1.36)    | 1.30<br>(1.13-1.46)    | 1.39<br>(1.20-1.57)    |
| 15-min   | 0.699<br>(0.626-0.778)             | 0.814<br>(0.730-0.902) | 0.922<br>(0.825-1.02)  | 1.08<br>(0.965-1.20)   | 1.21<br>(1.08-1.35)    | 1.34<br>(1.19-1.49)    | 1.44<br>(1.28-1.60)    | 1.54<br>(1.35-1.72)    | 1.64<br>(1.43-1.84)    | 1.74<br>(1.50-1.97)    |
| 30-min   | 0.958<br>(0.858-1.07)              | 1.12<br>(1.01-1.25)    | 1.31<br>(1.17-1.45)    | 1.56<br>(1.40-1.73)    | 1.79<br>(1.60-1.99)    | 2.02<br>(1.79-2.24)    | 2.21<br>(1.95-2.46)    | 2.39<br>(2.10-2.67)    | 2.61<br>(2.27-2.93)    | 2.82<br>(2.43-3.19)    |
| 60-min   | 1.20<br>(1.07-1.33)                | 1.41<br>(1.27-1.56)    | 1.68<br>(1.50-1.86)    | 2.03<br>(1.82-2.26)    | 2.39<br>(2.13-2.66)    | 2.73<br>(2.43-3.04)    | 3.04<br>(2.69-3.39)    | 3.36<br>(2.95-3.75)    | 3.74<br>(3.25-4.20)    | 4.12<br>(3.55-4.65)    |
| 2-hr   | 1.47<br>(1.30-1.66)                | 1.73<br>(1.53-1.96)    | 2.08<br>(1.83-2.34)    | 2.53<br>(2.23-2.86)    | 3.00<br>(2.63-3.39)    | 3.45<br>(3.02-3.91)    | 3.88<br>(3.37-4.39)    | 4.31<br>(3.72-4.91)    | 4.86<br>(4.14-5.56)    | 5.39<br>(4.55-6.20)    |
| 3-hr   | 1.61<br>(1.42-1.82)                | 1.89<br>(1.68-2.14)    | 2.27<br>(2.00-2.57)    | 2.78<br>(2.44-3.15)    | 3.31<br>(2.90-3.75)    | 3.84<br>(3.34-4.35)    | 4.34<br>(3.74-4.92)    | 4.86<br>(4.15-5.53)    | 5.52<br>(4.66-6.32)    | 6.18<br>(5.15-7.11)    |
| 6-hr   | 1.98<br>(1.76-2.27)                | 2.33<br>(2.07-2.66)    | 2.78<br>(2.46-3.17)    | 3.40<br>(3.00-3.88)    | 4.09<br>(3.58-4.66)    | 4.79<br>(4.17-5.46)    | 5.47<br>(4.72-6.24)    | 6.19<br>(5.28-7.09)    | 7.15<br>(5.99-8.22)    | 8.12<br>(6.70-9.39)    |
| 12-hr  | 2.38<br>(2.12-2.72)                | 2.79<br>(2.48-3.18)    | 3.35<br>(2.96-3.80)    | 4.13<br>(3.65-4.69)    | 5.04<br>(4.42-5.72)    | 5.99<br>(5.21-6.81)    | 6.94<br>(5.97-7.91)    | 8.00<br>(6.78-9.15)    | 9.43<br>(7.81-10.8)    | 10.9<br>(8.88-12.6)    |
| 24-hr  | 2.75<br>(2.49-3.06)                | 3.35<br>(3.03-3.72)    | 4.35<br>(3.93-4.83)    | 5.21<br>(4.70-5.78)    | 6.53<br>(5.84-7.21)    | 7.69<br>(6.83-8.46)    | 9.00<br>(7.92-9.88)    | 10.5<br>(9.12-11.5)    | 12.7<br>(10.9-13.9)    | 14.7<br>(12.4-16.1)    |
| 2-day  | 3.16<br>(2.85-3.52)                | 3.85<br>(3.47-4.29)    | 5.00<br>(4.51-5.56)    | 5.99<br>(5.38-6.65)    | 7.48<br>(6.68-8.28)    | 8.79<br>(7.79-9.72)    | 10.3<br>(9.02-11.3)    | 11.9<br>(10.4-13.1)    | 14.4<br>(12.4-15.9)    | 16.6<br>(14.1-18.3)    |
| 3-day  | 3.33<br>(3.03-3.67)                | 4.04<br>(3.68-4.47)    | 5.23<br>(4.76-5.77)    | 6.24<br>(5.66-6.87)    | 7.77<br>(7.00-8.53)    | 9.09<br>(8.14-9.97)    | 10.6<br>(9.39-11.6)    | 12.2<br>(10.8-13.4)    | 14.7<br>(12.8-16.1)    | 16.9<br>(14.5-18.5)    |
| 4-day  | 3.49<br>(3.21-3.82)                | 4.24<br>(3.90-4.64)    | 5.46<br>(5.01-5.97)    | 6.50<br>(5.94-7.10)    | 8.05<br>(7.32-8.77)    | 9.39<br>(8.49-10.2)    | 10.9<br>(9.76-11.8)    | 12.5<br>(11.1-13.6)    | 15.0<br>(13.2-16.3)    | 17.2<br>(14.9-18.7)    |
| 7-day  | 4.04<br>(3.73-4.40)                | 4.88<br>(4.51-5.31)    | 6.18<br>(5.70-6.73)    | 7.29<br>(6.70-7.92)    | 8.92<br>(8.16-9.67)    | 10.3<br>(9.39-11.2)    | 11.9<br>(10.7-12.8)    | 13.6<br>(12.1-14.7)    | 16.1<br>(14.2-17.4)    | 18.2<br>(15.9-19.7)    |
| 10-day   | 4.53<br>(4.21-4.89)                | 5.44<br>(5.05-5.88)    | 6.78<br>(6.29-7.32)    | 7.89<br>(7.30-8.52)    | 9.49<br>(8.74-10.2)    | 10.8<br>(9.94-11.7)    | 12.3<br>(11.2-13.2)    | 13.8<br>(12.5-14.9)    | 16.2<br>(14.5-17.5)    | 18.3<br>(16.3-19.7)    |
| 20-day   | 6.06<br>(5.69-6.46)                | 7.20<br>(6.78-7.68)    | 8.71<br>(8.18-9.29)    | 9.94<br>(9.32-10.6)    | 11.6<br>(10.9-12.4)    | 13.0<br>(12.1-13.9)    | 14.4<br>(13.4-15.4)    | 15.9<br>(14.7-17.0)    | 18.0<br>(16.5-19.2)    | 19.7<br>(17.9-21.0)    |
| 30-day   | 7.55<br>(7.11-8.01)                | 8.94<br>(8.42-9.49)    | 10.7<br>(10.0-11.3)    | 12.0<br>(11.3-12.7)    | 13.9<br>(13.0-14.7)    | 15.3<br>(14.4-16.3)    | 16.8<br>(15.7-17.8)    | 18.4<br>(17.1-19.5)    | 20.4<br>(18.9-21.7)    | 22.0<br>(20.2-23.4)    |
| 45-day   | 9.56<br>(9.08-10.1)                | 11.3<br>(10.7-11.9)    | 13.2<br>(12.5-13.9)    | 14.7<br>(13.9-15.5)    | 16.6<br>(15.7-17.5)    | 18.1<br>(17.1-19.1)    | 19.6<br>(18.4-20.6)    | 21.0<br>(19.7-22.1)    | 22.8<br>(21.3-24.1)    | 24.2<br>(22.5-25.6)    |
| 60-day   | 11.4<br>(10.8-11.9)                | 13.4<br>(12.7-14.0)    | 15.5<br>(14.7-16.2)    | 17.0<br>(16.2-17.9)    | 19.0<br>(18.0-20.0)    | 20.5<br>(19.4-21.5)    | 21.9<br>(20.7-23.0)    | 23.2<br>(21.9-24.4)    | 24.9<br>(23.4-26.2)    | 26.1<br>(24.4-27.5)    |

<sup>1</sup> Precipitation frequency (PF) estimates in this table are based on frequency analysis of partial duration series (PDS). Numbers in parenthesis are PF estimates at lower and upper bounds of the 90% confidence interval. The probability that precipitation frequency estimates (for a given duration and average recurrence interval) will be greater than the upper bound (or less than the lower bound) is 5%. Estimates at upper bounds are not checked against probable maximum precipitation (PMP) estimates and may be higher than currently valid PMP values. Please refer to NOAA Atlas 14 document for more information.

[Back to Top](#)

## **APPENDIX H : STORMWATER MANAGEMENT SYSTEM OPERATIONS AND MAINTENANCE PLAN**

---

## STORMWATER MANAGEMENT SYSTEM OPERATION & MAINTENANCE PLAN

This Stormwater Management System Operations & Maintenance Plan (the Plan) outlines measures that are essential for maintaining an effective stormwater management system at the following:

*South Jersey Gas  
Interconnect Station  
Mount Pleasant Road  
Upper Township, New Jersey*

herein referred to as “the Site”. Periodic and scheduled inspection and maintenance measures are recommended to prevent deficiencies and to promote proper performance of the stormwater management system. Failure to implement these measures can reduce the hydraulic capacity of stormwater measures.

### RESPONSIBLE PARTY

The party responsible for implementing this Plan and identifying the source of necessary funds is as follows:

*South Jersey Gas  
One South Jersey Plaza  
Folsom, New Jersey 08037*

### INSPECTIONS & MAINTENANCE MEASURES

The stormwater management system at the Site consists of a 6 inch crushed stone infiltration area. Attachment A provides the Inspection Form that is recommended for use during routine inspections of the crushed stone infiltration area. The form includes a table that outlines specific inspection and maintenance measures, in addition to the following information:

- Name of inspector
- Name of the site and its location
- Date and time of inspection
- Weather conditions during inspection
- Outline of items inspected
- Condition of the stormwater management measures, including corrective measures taken to maintain the system

Completed Inspections Forms should be kept on file to enable both facility managers and regulatory agencies to ensure that operation of the system is in compliance with permit requirements.

## ATTACHMENT A – INSPECTION FORM



---

## STORMWATER MANAGEMENT SYSTEM INSPECTION FORM

*South Jersey Gas  
Interconnect Station  
Mount Pleasant Road  
Upper Township, New Jersey*

*Name of Inspector:* \_\_\_\_\_

*Date/Time:* \_\_\_\_\_

*Weather:* \_\_\_\_\_

*Date of Last Inspection:* \_\_\_\_\_

*Items Inspected (Refer to Table 1. Provide additional sheets if necessary.):*

---

---

---

---

---

---

---

---

---

---

---

*Comments & Corrective Actions Taken (Provide additional sheets if necessary.):*

---

---

---

---

---

---

---

---

---

---

---

**Table 1 – Operations & Maintenance Measures**

| <i>Crushed Stone Infiltration Area</i>  |   |
|---|---|
| <i>Objective: Maintain the infiltration capacity of the crushed stone infiltration area</i> |   |
| <i>Frequency</i>  | <i>Measure</i>  |
| Annually  | <ul style="list-style-type: none"> <li>• Remove and dispose any sediment and debris from crushed stone surface and contributing areas in accordance with all Federal, State and local regulations</li> <li>• Inspect surrounding areas for stabilization; contributing areas should be stabilized</li> <li>• Inspect crushed stone infiltration area for signs of clogging</li> <li>• Remove and replace areas of crushed stone as required</li> <li>• Inspect crushed stone infiltration area to verify that system dewateres between storm events</li> <li>• All repaired areas shall be restored according to original design specifications.</li> </ul> |